

# The Book

by  
TESUP

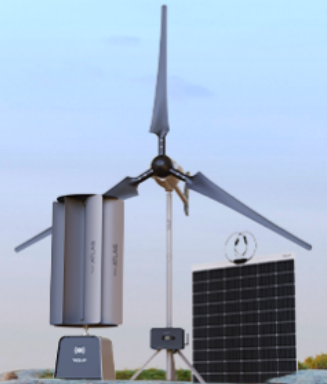

---

Your guide to get the most of your new TESUP product

# Welcome

Welcome to the world of TESUP and congratulations on your first step towards a more sustainable future!

We are delighted that you have chosen TESUP for your energy needs. Our innovative products are designed to help you save money, reduce your carbon footprint, and prepare for the future. By choosing TESUP, you are joining a large community that is committed to making a positive difference in the world.

“The Book” is a practical guide to provide you with all the information you need to maximise your energy production with your TESUP product and make you a part of our global community!

## The Book Contents

Safety & Warnings	4
About Us	7
Useful Information	12
Get Most of Your Product	12
Customer Care	13
Useful Resources	14
Product Manuals	17
<b>Wind Turbines</b>	17
Safety & General Instructions	17
Maintenance & Cleaning	24
ATLAS	27
MAGNUM	46
Mounting Pole	49
Charge Controller	57
<b>Flex Solar Panel</b>	63
<b>TESUP Wizard Sensor Terminal</b>	77
<b>Old Products</b>	85
TESUP V7	85
HERA WIND PRO	107
ATLAS 7	114
ATLAS X7	122
MASTER X	130
Frequently Asked Questions	141
Wind Turbines	141
Charge Controllers	146
Inverters	148
Flexible Solar Panels	149
Energy Systems & Connections	150
Warranty	152
Before You Go	154

First Things First:

# Safety & Warnings

# Safety & Warnings

## READ THIS BOOK

This book contains essential safety information. Regardless of whether you already have an energy system at home, it is crucial that you read and comprehend the contents of this book before using your new TESUP product(s).

## Important Safety Instructions

Before using your TESUP product please read all instructions, cautionary markings and watch any relevant assembly and installation videos that are mentioned in the [Product Manuals](#) section of this book. Additionally, please pay attention to any additional instructions or markings on the product packaging itself. When installing and using a TESUP product, it is always necessary to adhere to basic precautions, including paying attention to warning signs. These warnings are applicable to the product and, when relevant, to all associated tools, batteries, accessories, chargers, or adapters.

**To ensure safety and minimise the risk of fire, electric shock, or injury, please keep the following guidelines in mind:**

- TESUP products are not intended for use by individuals with reduced physical, sensory or mental capabilities, or those lacking experience and knowledge, unless they have received proper supervision or instruction from a responsible person regarding safe product usage.
- Do not allow children to use or play with TESUP products.
- All TESUP products are designed for outdoor use only. Do not install or use TESUP products indoors.
- Your TESUP product must be installed and used as described in the manual section of this book. Incorrect installation may result in product damage and void your warranty.
- Do not carry out any maintenance other than those shown in the manual, or advised by TESUP Customer Support Centre.
- **TESUP Wind Turbines should only be used with original TESUP Charge Controllers provided within the TESUP Wind Turbine box.** The company holds no responsibility for any damages that may occur as a result of connecting TESUP Wind Turbines to charge controllers manufactured by other companies.
- Take note of the wire size and fuse recommendations provided in the [Product Manuals](#) section.
- Ensure that your TESUP energy system (wind, solar or hybrid) is installed correctly by a suitably trained individual, preferably an experienced technician. It is crucial that all operating personnel have thoroughly read and understood the instructions included in this book.
- It is crucial that all operating personnel have thoroughly read and understood the instructions included in this book.
- TESUP will not accept any liability if the equipment has been altered, or in the case of improper assembly, installation, start-up, operation, maintenance, or repair.
- Any use of the equipment that deviates from or exceeds the limits described in this book is considered contrary to its intended purpose. Reasonable foreseeable misuse includes:
  - Operating the equipment outside the manufacturer's specifications.
  - Making modifications and changes to the wind turbine, solar or hybrid systems without the manufacturer's approval.

- Using non-approved spare parts and accessories that are not original.
  - Operating in energy system classes that are not approved.
  - Operating in strong winds and hurricanes (applicable to wind turbine systems)
- To ensure smooth operation without interruptions or overheating, it is important to maintain a constant load consumption in your energy system.
  - Your energy system must be properly maintained and repaired.
  - Check the components of your energy system regularly and make sure everything is functioning correctly.
  - **Refer to this book when needed in order to protect your warranty rights and for future reference.**



## Warning Signs Used in This Book

As you go through the manual sections of this book, you will come across the following signs:



**Warning** - This sign indicates potential danger that could result in serious or moderate injury, as well as critical information to ensure the safe operation of the products and prevent any damage to the product.



**Important** - This sign indicates that the information following it should be taken note of and should be read carefully.



**Quick Tips** - This sign provides useful information or recommendations to help you maximise the performance of your TESUP energy system or products and ensure they are working properly.

**Please pay attention to these signs.** They are in place because we prioritise your safety and the well-being of your loved ones, as well as the optimal performance of your TESUP products. We genuinely care about your safety and want you to experience the utmost efficiency from your energy system.



About Us

# About Us

We are a global company specialised in manufacturing renewable energy products for households. We proudly hold the position of being the global leader in the household wind energy products market. Our primary products are household wind turbines and semi-flexible solar panels.

TESUP was first established in 2016 in London, United Kingdom. But our renewable energy knowledge and expertise date back to 1974. Throughout the years, we have participated in numerous hydroelectric, wind, and solar power plant projects, contributing to a cumulative installed power capacity exceeding 1000 MW. Today, we operate in over 30 countries, featuring local warehouses, manufacturing facilities, and offices, with our headquarters located in London.

At TESUP, our ultimate mission is to become the global leader in providing clean energy products for households. We combine innovation, superior quality and simplicity, all while ensuring that our products are affordable for everyone.

We firmly believe that everyone should be able to transition to clean energy effortlessly and incorporate it into their sustainable lifestyle. Our goal is to enable every household to generate their own energy using TESUP clean energy products, with the ultimate aim of having these products installed in every home across the globe.

As a united international family at TESUP, with members from every continent, we work diligently to fulfil our vision. We continuously upgrade our products, expand our production capacity, explore new markets and prioritise customer satisfaction each day.



MORE THAN 100K CUSTOMERS WORLDWIDE

## Our Manufacturing Processes

At TESUP, our team of expert engineers and dedicated manufacturing associates are striving to establish TESUP as the world's leading manufacturer, known for its exceptional cleanliness and advanced technology. We continuously iterate and enhance our processes to ensure that TESUP remains at the forefront of innovation. When you purchase a TESUP product, it undergoes four main stages before it is delivered to your doorstep:



**Manufacturing:** We take pride in designing and manufacturing all of our products in-house. By doing so, we have complete ownership of our products' technology, allowing us to continuously enhance their quality and performance. Our manufacturing process utilises lean techniques, which prioritise waste reduction and efficiency optimization. This approach enables us to provide our customers with cost-effective solutions while minimising our environmental footprint.

1



**Quality Control & Testing:** We always use the top-quality materials for our products and have strict quality control standards to ensure consistency and superior quality. Our dedicated team of quality managers constantly monitors the manufacturing process. Each finished product undergoes assembly and rigorous testing to successfully pass our stringent quality check before it leaves our factory.

2



**Packing:** We are committed to delivering TESUP products to your doorstep in the best possible condition. In order to ensure this, we use strong plywood boxes to prevent any damage and use our special foam machine to fill any empty space within the box, providing product stability and preventing movement.

3



**Shipping & Delivery:** We work with the best international shipping companies to make sure that your products are delivered safely and promptly.

4

## Sustainability at TESUP

Sustainability is at the core of all our actions. Our primary focus is on minimising our impact on the environment while simultaneously delivering greater value to our customers, employees, and society as a whole.

Our products and packaging are predominantly made from recyclable and recycled materials, and we are continuously working towards increasing the proportion of recyclable materials used in our manufacturing processes. At all our production sites, we have implemented environmental management systems that drive ongoing development and optimization of our operations. These systems are aimed at reducing waste, water consumption, and electricity usage. By minimising our environmental impact, we not only contribute to a greener future but also enhance our ability to offer cost-effective solutions and provide greater value to our customers.

We have a strong commitment to repurposing and recycling. As an example, our plywood delivery boxes are designed to be durable and robust, allowing them to serve as eco-friendly storage containers once they have fulfilled their initial purpose. We also provide a free take-back service for end-of-life products, enabling us to reclaim valuable components and incorporate them into the production of new products.

Our aspiration and promise: By 2030, all TESUP products and packaging will be made from 100% recycled and recyclable materials. Furthermore, we strive to achieve complete energy independence in our production facilities by the end of 2028, generating all the energy required through our clean energy systems, ensuring a sustainable and environmentally-friendly manufacturing process.



### OUR BRAND PROMISE

Inspire everyone  
to **act sustainably**  
and make the world  
a better place.

TESUP

**OUR CSR PROJECTS**

In addition to our environmental sustainability initiatives, we are also a socially responsible company: both internally and externally. Our employees are treated with respect and compensated fairly. We prioritise investing in the personal and professional development of our employees, as well as encouraging them to live their life in a more sustainable way, and providing ongoing engagement activities for their motivation and happiness. Our employees are our most valuable asset and are leading the way in our transformation.

We are also deeply committed to making a positive impact on society as a whole through our corporate responsibility initiatives. As part of our efforts, we have supplied over 100 TESUP wind turbines to remote areas lacking electricity, particularly in Africa so far. To further demonstrate our dedication to assisting those in need, we have established an application form on our website to gather requests and continue sending more turbines. In addition, we contribute a significant annual donation to UNICEF to support children affected by disasters and conflicts. We also actively promote youth participation in sports by sponsoring two teams in the London Basketball League and supporting a prominent Basketball Academy in London.

For us, sustainability is more than mere words, it's about taking tangible action. We are committed to finding the right balance between economic, ecological, and social needs every day. This holistic approach not only ensures the creation of exceptional products for our customers but also motivates them to adopt responsible practices.





# Useful Information

# Useful Information

## Get Most of Your Product

### *10 Things that every TESUP user should know*

We understand that not everyone is a technical expert, but every TESUP user should know these 10 essential things:

- 01 Use the original TESUP products to get the best performance.** TESUP wind turbines are tested with TESUP charge controllers and TESUP-recommended inverters. Connecting your turbine to a low-quality, inexpensive charge controller may lead to reduced performance and could potentially cause system failure or breakdown. Please note that such issues are not covered by your warranty.
- 02 Read the rest of this book.** These products involve technology, require electrical connection and must be handled with care and caution. Moreover, our experience of manufacturing and selling renewable energy products for over 10 years has taught us valuable knowledge and insights worth sharing, which we have included in this book.
- 03 Know your products.** Watch installation and assembly videos, and read all the information provided about your product in this book.
- 04 Go online to get more information.** The online version of this book is regularly updated. If you can't find an answer to your question, please check out the online version or contact us via [Support](#) page.
- 05 Choose the ideal product combination for your location.** It's crucial to be aware of the average wind speed, temperature, and cloud cover rate in your area. This information will help you determine

whether you require a wind, solar, or hybrid system to maximise energy generation. Almost every country has an official website where you can access this data. Alternatively, our consultants can also assist you in determining the ideal product combination based on your location and circumstances.

- 06 Understand the difference between off-grid and on-grid systems and decide which one is best for you.** On-grid systems are connected to the electricity grid, allowing them to rely on grid power when needed and sell excess energy back. Off-grid systems, while potentially more expensive, offer energy independence and rely on batteries to store excess energy for use when renewable sources are not generating power.
- 07 Place importance on connections.** Be careful while connecting different energy systems and inverters. Exercise caution and take necessary precautions while connecting these components. The proper alignment and secure attachment of cables, wires, and connectors are essential to ensure the smooth and efficient operation of the systems.
- 08 Cabling - pay attention to the lengths and cross-section of the cables.** Be careful while connecting cables. When it comes to cabling, it's important to consider the lengths and cross-sections of the cables. Taking the time to properly connect and secure the cables will help maintain a safe and efficient electrical system.
- 09 Always get a technician's help for installation.** By getting help from a professional you can get the most yield of your product. Investing in professional installation ensures that all aspects, such as wiring, connections, and setup, are handled accurately and in accordance with industry standards.
- 10 Check all screws.** Ensure that all screws are securely tightened to prevent any vibration.

## Customer Care

At TESUP, we are dedicated to providing exceptional customer care and support to all our customers. We understand that investing in renewable energy solutions can be a significant commitment, and we strive to ensure our customers' satisfaction with their purchase.

### CUSTOMER CARE AND SUPPORT SERVICES

At TESUP, we pride ourselves on our exceptional customer care and support services. We understand that our customers may have questions or need assistance with their products, and we are always ready to help.

We offer a range of customer care and support services, including:

**Individual Consultancy:** Our experienced and knowledgeable team is always available to provide online one-to-one consultancy to our customers. Whether it's answering questions, providing guidance on installation, or troubleshooting issues, our team is here to help. We assist customers who have specific renewable energy projects they want to bring to life. Our experts will work closely with you to understand your requirements and provide tailored advice and guidance.



### Renewable Energy Lectures:

We offer free lectures to educate our customers about renewable energy. These courses are 45 minutes each and are repeated weekly with a changing program.

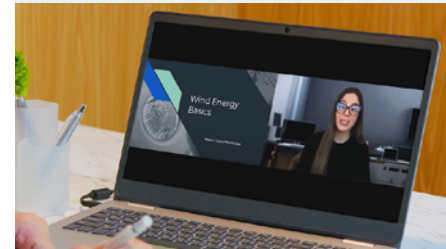

### Product Service Appointment:

We offer technical support to our customers as well. Our team of technical experts are available to provide assistance with any product-related issue or query you may have.

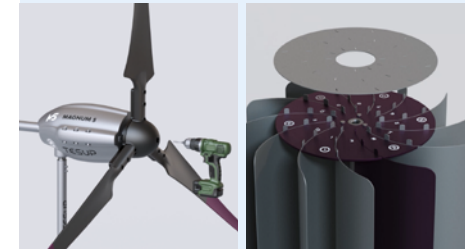

At TESUP, our commitment to exceptional customer care and support sets us apart. We believe that by providing comprehensive assistance and guidance, we can enhance your experience and make us the preferred choice for your renewable energy needs.



## WARRANTY AND RETURNS POLICY

Our products come with a standard 2-years warranty, and customers have the option to extend the warranty for an additional fee. If any manufacturing defects or issues arise within the warranty period, we will repair or replace the product at no cost to the customer.

Each TESUP product features custom-built software personalized with the customer's name. Please be aware that once an order is placed and processed, modifications to the software remotely are not possible, and consequently, we do not offer refunds.

For products under warranty experiencing manufacturing defects or malfunctions, customers must send them to our London repair center for examination. Our dedicated team handles repairs with precision, providing a comprehensive report for each case. While shipping costs for returns are the customer's responsibility, if the fault is attributed to the production process, these costs will be reimbursed. In such cases, a new replacement product with free delivery will be promptly sent.

For any inquiries, please reach out to them by logging into our **Support Page** and selecting the **'Chat'** option located at the far right end of the page. Our team of engineers is available to assist you in resolving any concerns you may have. They can help explore options such as providing a replacement or assisting with the purchase of new spare parts if needed. Rest assured, we are committed to finding a solution that addresses your specific needs and ensures your satisfaction.

To maintain product uniqueness and integrity, each product is tagged with your name and a unique serial number, with operational test videos recorded. This ensures that boxes cannot be shipped to other customers.

We appreciate your understanding and cooperation in these matters as we strive for maximum customer satisfaction and work towards creating exceptional and environmentally-friendly products.

## Useful Resources & How to Get in Touch

TESUP aims to respond to all messages within the first 24 hours. You can access our local TESUP team via website contact pages: [tesup.com](https://tesup.com). In order to discuss your order, visit the Support page, log in to your account, to initiate a chat.

TESUP operates in over 30 countries worldwide. To access our local websites, please visit [tesup.com](https://tesup.com).

## VIDEO LIBRARY

Find out more about our company and products from our [Youtube Channel](#). You can find videos of product installations, customer reviews, our brand values, and TESUP team.

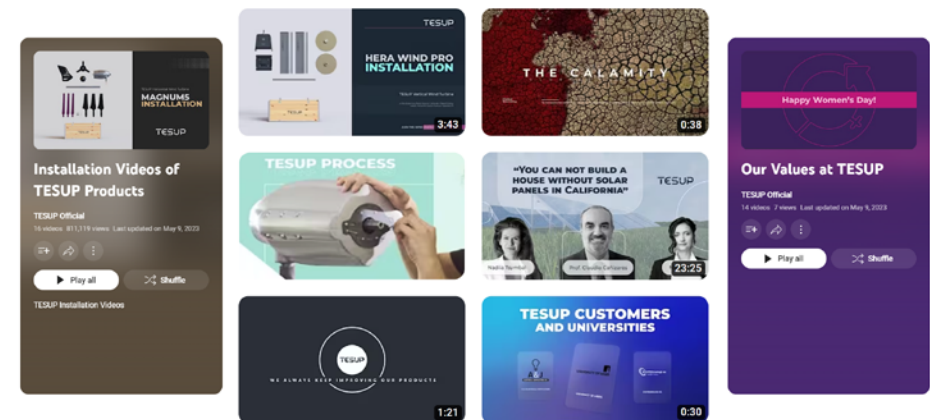



# Product Manuals



Product Manuals

# Wind Turbines

# Wind Turbines

## Important Safety Instructions

- **All TESUP products are for outdoor use only.**
- Don't forget to:
  - Tighten all fasteners properly. Check and tighten all fasteners every 3 months or after experiencing extreme weather conditions.
  - Use grounding techniques as established by the NEC.
  - Properly install the wind turbines and solar panels in accordance with this manual and local and national building codes. This is imperative to ensure warranty coverage. Noncompliance with these guidelines may result in the warranty becoming void.
  - If an abnormal vibration is observed in your system, the turbine should be stopped immediately until the problem is solved, to avoid possible injuries or any damage to the turbine. Once the system is completely shut down, check and tighten all fasteners on the turbine before turning your system on again.
  - Observe wire size and fuse recommendations listed in the [Wiring Section](#) of this manual.
- Wind turbine rotating blades pose a significant mechanical hazard. To ensure safety, the installation of wind turbines must be done in a manner that eliminates any possibility of contact with the blades.
- Please note that the system is specifically designed for operation in Class III wind sites and should not be used in any other wind class. Operating the system in wind classes that are not approved poses a significant risk to life.



**WARNING:** The wind turbine system may involve high wind speeds, high voltages, and high temperatures. To ensure safety, it is crucial to use fire-resistant cables exclusively.



**IMPORTANT:** To operate the system, the TESUP Wind Turbine, TESUP Charge Controller, and an inverter are all required and must be installed outdoors.

## PERSONNEL REQUIREMENTS

All work on the wind turbine systems must be carried out by authorised individuals. These individuals must have a comprehensive understanding of the safety devices and regulations before undertaking any work. Authorised personnel are defined as follows:

Operating mode	Necessary qualifications
Erection	Suitably trained persons
Normal operation	Trained personnel
Cleaning	Trained personnel
Maintenance	Suitably trained persons
Repair	Manufacturer

## MODIFICATIONS BY THE USER

To ensure compliance with the European Machinery Directive 2006/42/EC, it is essential that only original TESUP product components are used and the wind turbine system is properly erected. The use of components from other manufacturers or any modifications or changes made by the user is strictly prohibited. Such actions could invalidate the declaration of conformity.

## RESIDUAL RISKS

The user manuals in this book includes relevant sections that describe any residual risks that may arise during operation or maintenance of the wind turbine system.

## General Instructions

Before you begin installing your wind turbine, read the entire user manual section of this book. Following the instructions and recommendations in this manual section will help assure safe and enjoyable use of your new renewable energy system. Please take the time to read through this manual prior to assembly.

- TESUP Wind Turbines can only be used with TESUP Charge Controllers.
- To ensure smooth operation without stopping and overheating, there must be constant load consumption for the wind turbine system (wind turbine, charge controller, and inverter). Therefore, we recommend grid-connected systems only.
- Wind turbines, charge controllers and inverters should be installed outdoors.
- Wait for a calm day to install or perform maintenance on your turbine with the brake activated.
- Listen to your turbine, if you hear any mechanical noise, maintenance may be required, please contact your turbine seller.
- After installation, re-adjust and tighten the screws and bolts.
- Adhere to proper grounding techniques as established by the National Electrical Code.
- Your wind turbine must be installed in accordance with this manual as well as local and national building codes. Incorrect installation may void your warranty.
- Be aware that wind turbine blades rotate at a potentially dangerous speed, and thus, proper caution must be exercised. Never approach a wind turbine that is in motion.
- Prior to wiring, ensure that the wire size is appropriate. Undersized wires can be potentially hazardous.
- Periodically check the manual brake according to the instructions provided in the manual.
- Check the health of the battery periodically. Low voltage or improper connection can cause over-spin issues, which can be potentially dangerous.
- TESUP Wind Turbines should only be used with original TESUP Charge Controllers. The company holds no responsibility for any damages that may occur as a result of connecting TESUP Wind Turbines to charge controllers manufactured by other companies.
- Take note of the wire size and fuse recommendations provided in the product manuals section.



**WARNING:** Do not open the wind turbine body or expose the generator unless instructed to do so by a TESUP engineer. Opening the turbine body or making modifications to the turbine system will result in voiding of your warranty.

## OPERATING & INSTALLING CONDITIONS

Please make sure that:

- The wind turbine system has been erected correctly by a suitably trained person
- All operating personnel have read and fully understood this translation of the original instructions
- The wind turbine system is properly maintained and repaired

## PRODUCT FEEDBACK

Please notify the manufacturer or their authorised representative about any of the following:

- Accidents
- Potential safety hazards associated with the wind turbine system
- Uncertainties arising from the translation of the original instructions.

## INTENDED USE

- The wind turbine system may only be used as a “small wind turbine system” (SWTS) to generate power in accordance with EN 61400-2.
- The wind turbine system must be operated strictly in accordance with its ratings and within the approved wind class, as specified in the technical data.
- Compliance with the original instructions and adherence to the maintenance and repair procedures are essential prerequisites for using the wind turbine system for its intended purpose.

## REASONABLY FORESEEABLE MISUSE

- To ensure the best performance and safety of your TESUP turbine, it's important to adhere to the recommended guidelines. Any usage that goes beyond these guidelines may not only compromise the intended purpose but also release the manufacturer from liability for any resulting damages.
- For the best protection and peace of mind, it's essential to understand that the manufacturer cannot assume responsibility for any damages that may occur due to equipment alterations or improper assembly, installation, start-up, operation, maintenance, or repair.
- To maximise performance and reliability, it is strongly recommended to use only original parts supplied by the manufacturer as spare parts or accessories. Non-approved parts or accessories might lack proper testing and could potentially result in reliability issues. Please note that the manufacturer cannot be held responsible for any damages that may arise from the use of non-approved parts or accessories.
- To ensure the longevity and optimal performance of the wind turbine system, it's important to be aware of certain foreseeable misuses to avoid. These include:
  - Operating the system outside the manufacturer's specified parameters.
  - Making modifications or changes to the wind turbine system without obtaining written approval from the manufacturer.
  - Using non-original parts that are not recommended by the manufacturer.
  - Operating the system in non-approved SWTS (Small Wind Turbine System) classes.
  - Operating the system during strong winds or hurricanes.

By adhering to the manufacturer's guidelines, you can safeguard the wind turbine system and enjoy its benefits for years to come.

## Storage & Operation

### STORAGE

**Ambient temperature:**

-15 to +40°C.

**Storage location:**

Dry, frost-free

### OPERATION

**Ambient temperature:**

-25 to +40°C.

**Place of use:**

Max. SWTS Class III acc. to EN 61400-2.

Our wind turbine systems are designed specifically for small-scale power generation, known as Small Wind Turbine Systems (SWTS), in accordance with EN 61400-2. Our products are suitable for generating low voltage power, with a maximum voltage of 75V achievable using the TESUP Charge Controller. It is important to always operate our wind turbines with a charge controller. We are constantly improving our technology, and our latest wind turbines are capable of generating more than 100 volts in high winds, with some products even at wind speeds as low as 10 m/s.

The TESUP Charge Controller allows for adjustable and limited output voltage levels, ranging from 0 to 400 volts. However, if the inverter option is selected using the button on the TESUP Charge Controller, there is no maximum voltage limitation. For safety, our products are labelled with stickers warning of electrical danger. We do not accept responsibility for any health risks associated with the use of electricity.

In on-grid systems, an inverter is a crucial component that converts the DC power transferred by the charge controller into AC power suitable for use in homes or the electrical grid. Please note that the inverter needed for on-grid systems must be supplied separately.

The Company (TESUP) cannot be held responsible for any modifications or external damages that may affect voltage generation. While we make every effort to ensure that our product descriptions, pictures, information, and prices are accurate, we do not accept liability for any inaccuracies, errors, or omissions. We also do not accept liability for any inaccuracies resulting from incorrect usage of TESUP products. Additionally, we do not take responsibility for installation and modification mistakes for products that are delivered disassembled. Please note that colours may slightly differ from those shown on the website due to limitations of internet, software, and computer hardware technologies. As part of our commitment to continuous product improvement, TESUP reserves the right to change or modify product specifications without prior notification.

## Pre-use Preparation

### SHIPPING CONDITIONS

The wind turbine system is shipped in a disassembled state. Please refer to the contract documentation for the specific scope of supply.

### PRE-REQUISITES AT THE PLACE OF USE

There are certain prerequisites that need to be followed at the place of use. Please review the specifications provided regarding the required footprint, minimum clearances, and installation conditions.

### PERMISSIBLE WIND CLASS AND MINIMUM CLEARANCES

For information regarding the local wind classes, it is recommended to contact the responsible authorities or your nearest meteorological office.

When selecting the location for the wind turbine, it is important to ensure that the place is free from obstacles or that the turbine is installed at a sufficient height to avoid obstructions. For home use, a suitable location could be on top of the house or terrace, where the turbine can function properly.



**WARNING:** Operating the wind turbine system in non-approved wind classes can pose a danger to life. Therefore, the wind turbine system should only be operated in wind sites up to Class III.



**IMPORTANT:** When choosing the place of use, ensure that there is enough space available to tilt the tower and blades when necessary. This is crucial for maintenance and servicing purposes.



**WARNING:** Danger up to 120V during storms.



**IMPORTANT:** Please cover wind turbine blades, if a hurricane in the scale III (50-58 m/s) or above occurs.

## Electrical Connections

[Click](#) to watch electrical connections. Wind Turbine has 3 phase AC connection. These connections are to be connected with TESUP Charge Controller.

The output of the charge controller can be then connected in two ways:

1. The Output of the charge controller can be connected to the battery.
2. The Output of the charge controller can be connected to the power grid using the inverter.

The cables from charge controller to the battery or the power grid will be DC connection. Cable lengths and cross sections should be as follows:

Length	<11 m	<18 m	<29 m	<44 m	<68 m	<110 m
Cross-section	2.5 sq. mm	4 sq. mm	6 sq. mm	10 sq. mm	16 sq. mm	25 sq. mm



**WARNING:** All electrical work must be performed by a qualified electrician with the power switched off.



**QUICK TIP:** To ensure proper operation, you must use an original TESUP charge controller.

## Regular Operation

To switch on the wind turbine system, follow these steps:

- Unlock the emergency stop button or release the brake button on the TESUP charge controller.
- The brake will be released.
- The fast-blinking red LED on the TESUP charge controller will turn off.
- The wind turbine system will start supplying power.

To restart the wind turbine system after an emergency, follow these steps:

- Ensure that the risk or emergency situation has been fully addressed and removed.
- Refer to the previous paragraph for instructions on how to switch on the wind turbine system.
- Follow the appropriate procedures and safety precautions to safely restart the system.



**QUICK TIP:** For detailed information on operating the charge controller, please refer to the separate instructions provided specifically for the [charge controller](#).

## Shutting Down Wind Turbines

To perform an emergency shutdown of the wind turbine system, follow these steps:

- Switch the brake on your TESUP Charge Controller to position. This will activate the brake and short-circuit the wind turbine via the TESUP Charge Controller.
- Cover the blades or remove them and store them in a dry place.

To temporarily shut down the wind turbine system, follow these steps:

- Switch the brake on your TESUP Charge Controller to position. This will activate the brake and short-circuit the wind turbine via the TESUP Charge Controller.
- This type of shutdown is typically done during stormy weather when the wind speed exceeds 27 m/s. If the wind speed exceeds 27 m/s, it is recommended to cover the blades for added protection.

### AUTOMATIC BRAKE

The TESUP Charge Controller features an automatic brake function that effectively slows down and regulates the wind turbine's rapid acceleration. To activate the auto-brake function, please follow these steps:

- Use your charge controller in battery mode.
- Adjust the maximum voltage setting using the potentiometer button.
- When the wind turbine reaches the maximum voltage value set by the potentiometer, it will automatically activate the braking mechanism.



**QUICK TIP:** In inverter mode, there is no maximum voltage limitation.

# Troubleshooting & Diagnostics

## ISSUES, POSSIBLE CAUSES & ACTIONS

	Possible Cause	Possible Actions
1. Wind turbine does not start up	Not enough wind	Observe on a windy day with min 6 m/s wind speed.
	Manual brake switch on CC is in position '1'	Bring manual brake switch to position '0'.
	Short circuit	Check all cables and electrical connections.
	Use of hybrid inverter	Remove all third party equipments.
	Battery fully charged and stored electricity is not consumed	Discharge your battery.
	Low voltage set with potentiometer	If your product is in battery mode, the potentiometer will be active. If the red light is on, please correct your potentiometer settings.

	Possible Cause	Possible Actions
2. Rotors turn too slowly	Rotor blades incorrectly attached	Check the user manual to make sure blades are correctly attached.
	Blades are not balanced	-Balance the rotor blades. -Check the screws 'at least' every 3 months.
	Rotor cannot turn freely	Contact the manufacturer.
	Unfavorable location or in a situation where turbulence occurs	-Check and move to another location if necessary. -Provide the turbulence-free conditions.

	Possible Cause	Possible Actions
3. Wind turbine vibrates on tower (if applicable)	Rotor not balanced	Balance the rotor
	Abnormal vibration observed in the system	Make sure all screws and bolts are fastened properly and checked in every 3 months
	Tower not aligned vertically	Align the tower vertically
	Tower bends in the wind	Support your tower with stainless steel wire ropes.
	Tower foundation has too much clearance	Make sure you have a robust tower.

	Possible Cause	Possible Actions
4. Wind turbine system produces too little power	Wind turbine or CC defective	Contact the manufacturer
	Not enough wind	Observe on a windy day with min. 6 m/s wind speed.
	Battery defective (if applicable)	Replace the battery.
	Battery too small (if applicable)	Use a larger battery (Min. recommended battery capacity is 48V - 200 Ah).
	System fuse tripped (if applicable)	Remove 'Fuse connections' between wind turbine, Charge Controller and Inverter.
	Cable cross-section does not match installed cable length	Match the cable cross-section correctly
	Low energy consumption at the end of the system	Make sure to have enough consumption at the end of the system not to slow down the turbine.

## Maintenance & Cleaning

### SAFETY PRECAUTIONS DURING MAINTENANCE

Shut down the wind turbine system prior to all maintenance work.

### INSPECTION & MAINTENANCE SCHEDULE

Interval	Component	Activity
Daily	Wind turbine	Check for abnormal noises
	Rotor blades	Check that the blades turn freely
	Tower	Inspect for damage
At three months intervals / at the end of winter or after extreme weather events	Rotor blade	Inspect for cracks / damage and if necessary, replace
		Treat with underbody protection wax
		Are the rotor blades balanced?
	Mounting Base	Check for unusual vibration
		Check the guy wires
		Is the Base mounted properly?
		Inspect for damage
	Wind Turbine	Check the fasteners and tighten if loose
	Electrical Wiring	Inspect the cables for damage

Refer to the supplementary documents for information on maintaining supplier components.

### MAINTENANCE & CLEANING BY THE USER

It is recommended to regularly apply a coating of commercially available wax to the wind turbine and rotor blades.



**WARNING:** Always ensure to shut down the wind turbine system before performing any maintenance work. It is crucial to stop the turbine in low wind speed conditions.



**WARNING:** Risk of injury when carrying out maintenance work!  
Secure the wind turbine system to prevent unauthorised activation during maintenance work.



**WARNING:** If the rotor blades or electrical wiring are damaged or if there is an unusual vibration, it is crucial to shut down the wind turbine system immediately.



**QUICK TIP:** Applying a wax film to the wind turbine and rotor blades provides weather protection and enhances blade efficiency.

## Removal From Service & Disposal

It is important to note that the system must be dismantled and disposed of properly by a qualified professional.

Caution should be taken due to potential stored energy and the possibility of breakage.



**WARNING:** Risk of injury during dismantling

### FINAL DECOMMISSIONING OF WIND TURBINE SYSTEM:

1. Shut down the wind turbine system as described in [Shutting Down Wind Turbine Section](#).
2. Get the assistance of a qualified electrician to properly disassemble and deactivate the electrical systems and equipment.
3. Ensure that all rotors are properly braked.
4. Carefully tilt the tower under controlled conditions.
5. On the ground, detach the rotor blades from the generator.
6. Disconnect the generator from the tower and disconnect the electrical wiring.



**WARNING:** Risk of injury and potential breakage may occur if the wind turbine system is dismantled by unqualified individuals without suitable training. It is crucial to dismantle the system correctly by a qualified person to ensure safety and prevent damage.

## DISPOSAL OF THE WIND TURBINE SYSTEM AND COMPONENTS

Dispose of the individual components in accordance with the guidance of the responsible local authorities, as needed.

Wind Turbine System	
Wiring, electrical components	Dispose of as electronic scrap
Mechanical components	Segregate prior to disposal



**WARNING:** Stored energy



**QUICK TIP:** Take note of the relevant parameters at the site and keep them readily available when contacting the manufacturer or specialist dealer.



# Atlas

Vertical Axis Wind Turbine

# Atlas

## SYSTEM COMPONENTS

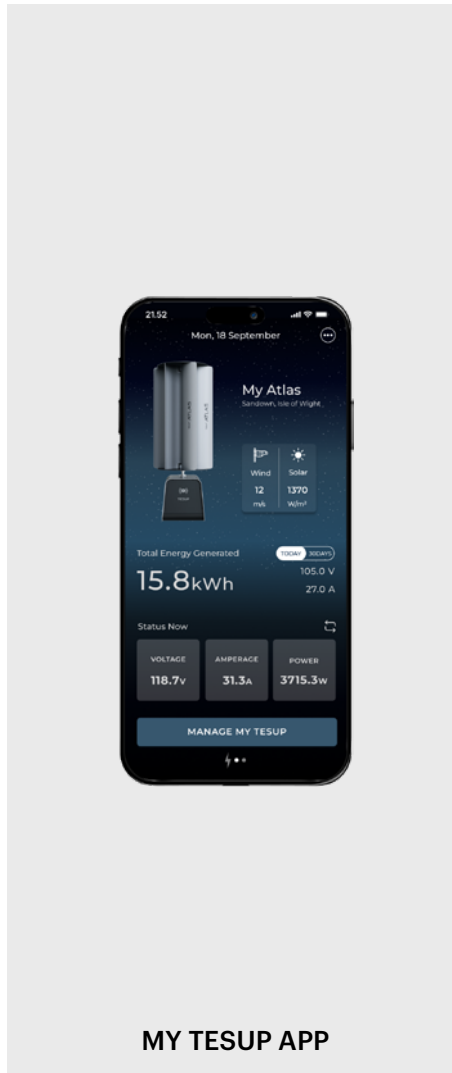

## DIFFERENT ATLAS BLADE SETS

### INCLUDED IN THE BOX

**High Wind  
Speed Blades**

Optimum Performance  
Between 5 - 35 m/s



### INCLUDED IN THE BOX

**Moderate Wind  
Speed Blades**

Optimum Performance  
Between 4 - 25 m/s



### OPTIONAL

**Low Wind  
Speed Blades**

Optimum Performance  
Between 2 - 20 m/s



WIND TURBINE COMPONENTS

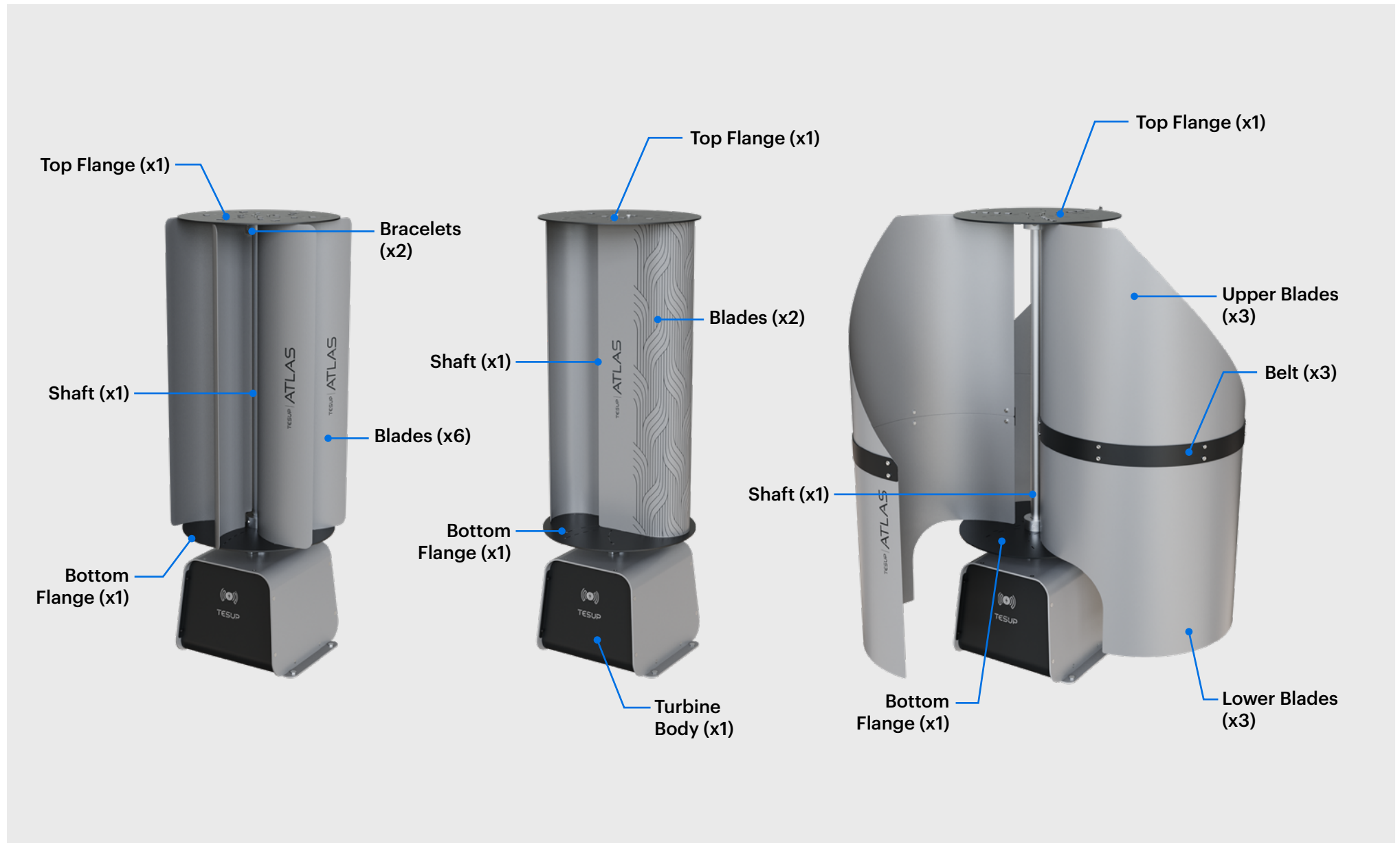

**PARAMETER & DIMENSIONAL DETAILS**

<b>GENERATOR</b>	
Material	Silisium sheetmetal
Type	Permanent magnet generator
Weight	20 kg (44 lbs)
Max. Power	15 kW motor-rated*, easy 1 kW power *Motor-rated power. Actual wind turbine output varies depending on wind speed, blade set and installation conditions.
Max. RPM	2000
Output voltage	Voltage can be adjusted by the built-in Charge Controller
Direction of Rotation	Both clockwise and counterclockwise
Charge Controller	Built-in, digital and manual voltage adjusment
Test Standards	EN 61000-6-1 (electromagnetic compatibility – immunity) EN 61000-6-3 (electromagnetic compatibility – emissions)

<b>HIGH WIND SPEED BLADES</b>	
Material	Aluminium
No. of Blades	6
Diameter	460 mm (1.50 Feet)
Weight Per Rotor Blades	100 g (0.22 lbs)
Direction Of Rotation	Clockwise
Operational Wind Speed	5 to 35 m/s
Noise	40 dB

<b>MODERATE WIND SPEED BLADES</b>	
Material	Aluminium
No. of Blades	2
Diameter	400 mm (1.31 Feet)
Weight Per Rotor Blades	850 g (1.87 lbs)
Direction Of Rotation	Clockwise
Operational Wind Speed	4 to 25 m/s
Noise	35 dB

<b>LOW WIND SPEED BLADES</b>	
Material	Aluminium
No. of Blades	3
Diameter	1030 mm (3.38 Feet)
Weight Per Rotor Blades	750 g (1.65 lbs)
Direction Of Rotation	Clockwise
Operational Wind Speed	2 to 20 m/s
Noise	35 dB

POWER CURVE



TESUP

TESUP 10 KW GENERATOR - ELECTRICAL POWER CURVE

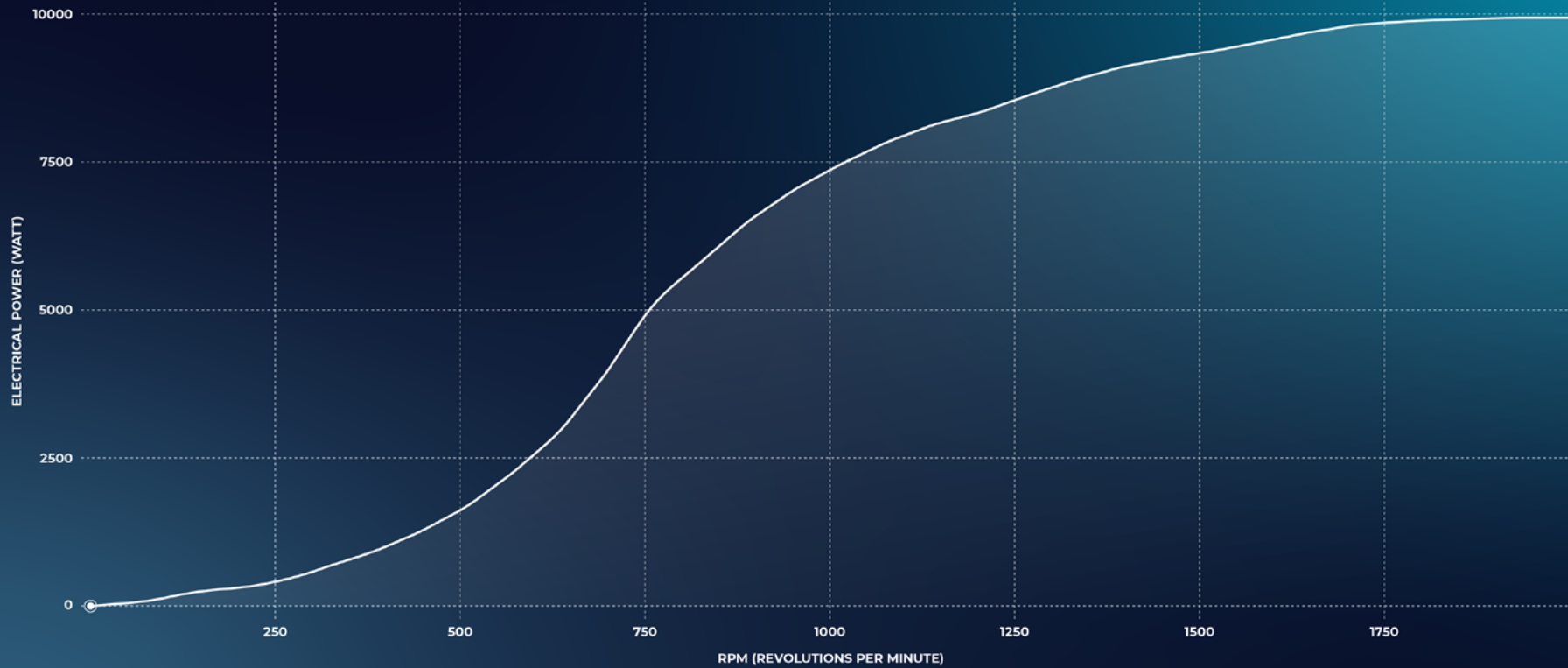

*Graph values represent ideal conditions in the initial month but may decrease over time (4% annually under Standard Test Conditions). Variation depends on location and external factors.*



**IMPORTANT:** Humidity, turbulence and the ion levels in the air can impact your turbine's performance.

GENERAL ARRANGEMENT AND DIMENSIONS

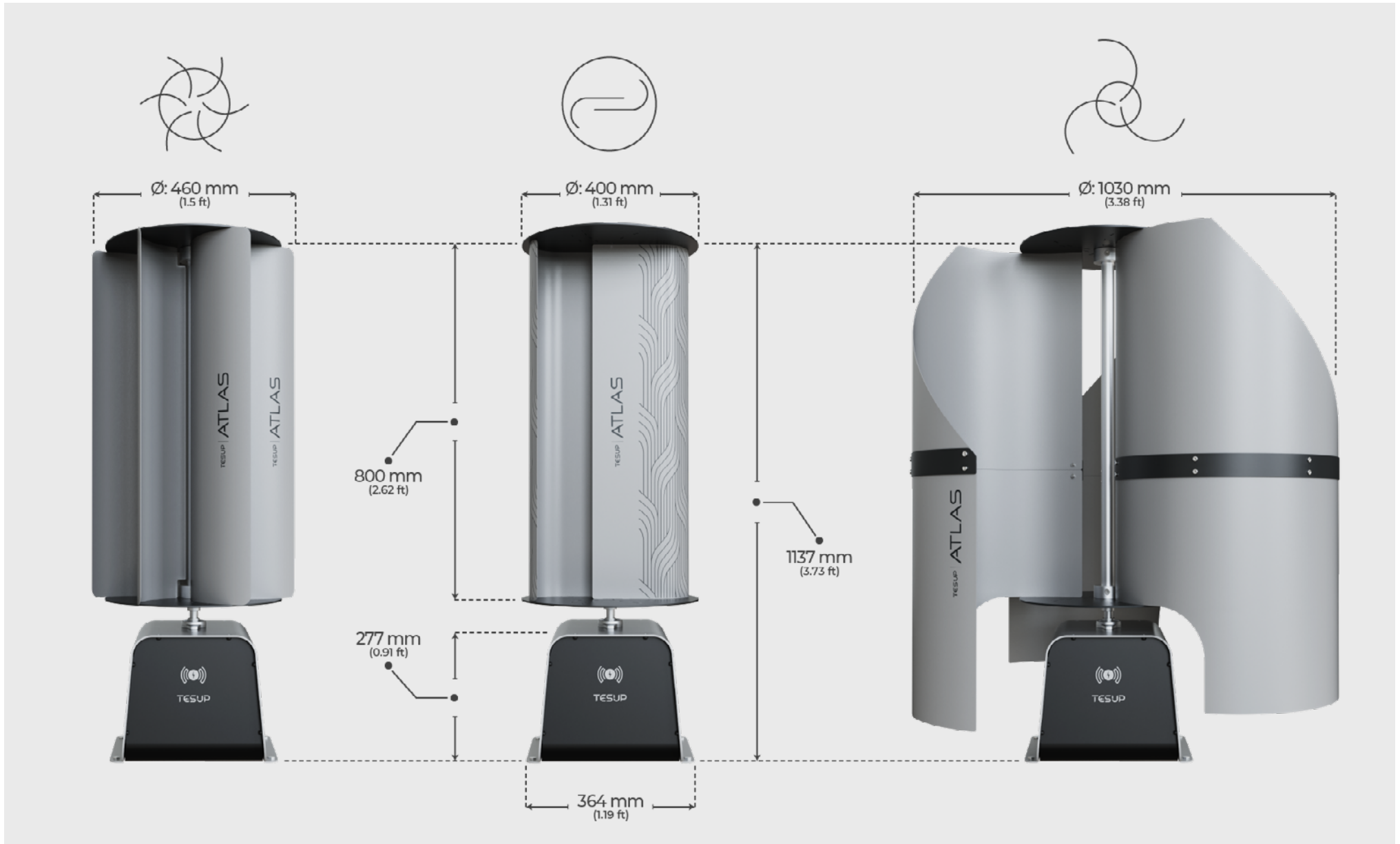

## Assembling the Wind Turbine

### MOUNTING DETAILS

The mounting surface must have a sufficient load-bearing capacity. The size and structure of the foundation depend on the ground/surface characteristics.

[Click here](#) to watch the ATLAS turbine assembly video.

Fastening packs available in your package and you will be using for the mounting base assembly:

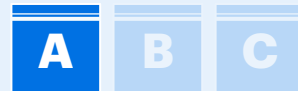

1. Carefully open the packaging, taking care not to damage any of the components. After verifying the shipment for completeness, carefully remove all components from the box.
2. Fix the mounting base to the turbine's final location.



**QUICK TIP:** It is recommended to consult with a qualified structural engineer for advice on determining the optimal mounting surface.



**WARNING:** The mounting base of the wind turbine must be fixed to the mounting surface and checked that it is fully stable, before moving on to the next steps with wind turbine installation.



**WARNING:** Before proceeding with the blade set installation, ensure that the mounting base is securely fixed to the mounting surface and thoroughly checked for stability.

[High wind speed blades assembly >>>](#)

[Moderate wind speed blades assembly >>>](#)

[Low wind speed blades assembly >>>](#)

## ASSEMBLING THE HIGH WIND SPEED BLADES

[Click here](#) to watch the ATLAS turbine assembly video.

Fastening packs available in your package and you will be using for this blade set's assembly:



1. Carefully open the packaging, taking care not to damage any of the components. After verifying the shipment for completeness, carefully remove all components from the box.
2. Fix the turbine body to the turbine's final location. Ensure that the mounting base is securely fixed to the mounting surface and thoroughly checked for stability. [Click here](#) to see the mounting details.

3. Insert the shaft on the rotor shaft (The double holes of the shaft should be on the downside, and the single hole should be on the upside.).



4. Mount the bottom flange to the shaft.

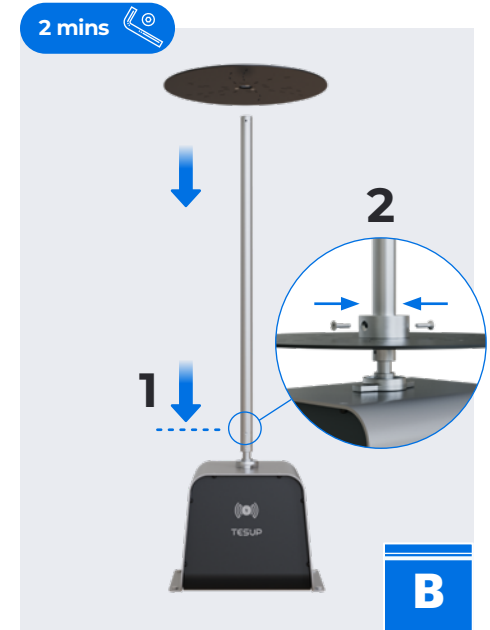

5. Mount the upper bracelet to the shaft.

Make sure of two things: The holes on the collar must overlap the holes on the top flange where they will be connected. The holes on the upper flange and the lower flange must also be aligned with each other.



**6.** Insert the turbine blades into the designated housings on the bottom flange, which are marked with the letter “H” for this blade set.

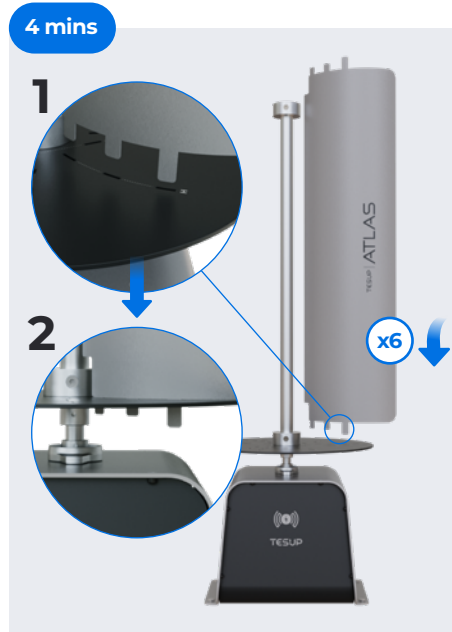

**8.** Carefully bend all the top snaps on the blades using a mallet.

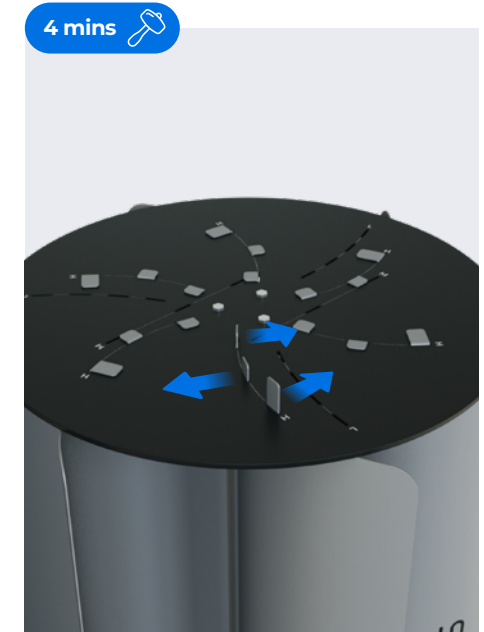

**7.** Insert the top flange and ensure that all the snaps pass through the housings marked with “H” on the top flange. Afterwards mount the top flange to the upper bracelet.



**9.** Turn the upper body upside down. Holding it from both the top and bottom flanges, carefully place the upper body on a flat surface with the top flange facing the floor.

Carefully bend all the bottom snaps on the blades using a mallet.



**10.** Flip the upper body, making sure the top flange is facing up again. Insert the shaft on the rotor shaft.



**11.** Fix the upper body to the base, using the grub screws provided.

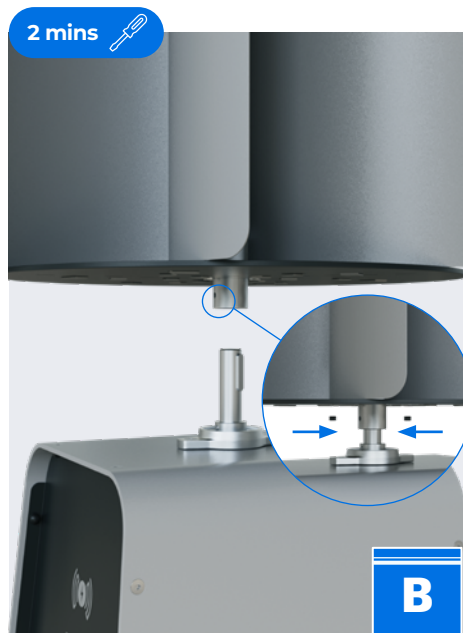

**12.** If there is a battery in the system (in the case of off-grid connections), the maximum voltage value must be manually adjusted either through the “Manage My TESUP” section in the My TESUP App or using the rotary encoder on the body.



**IMPORTANT:** If a short circuit occurs, the turbine will activate its braking system, preventing the blades from turning.



**WARNING:** Incorrect or loose fastening can adversely affect the efficiency of your turbine, potentially causing damage and posing a risk of injury. Ensure that all fasteners are properly tightened.

## ASSEMBLING THE MODERATE WIND SPEED BLADES

[Click here](#) to watch the ATLAS turbine assembly video.

Fastening packs available in your package and you will be using for this blade set's assembly:



1. Carefully open the packaging, taking care not to damage any of the components. After verifying the shipment for completeness, carefully remove all components from the box.
2. Fix the turbine body to the turbine's final location. Ensure that the mounting base is securely fixed to the mounting surface and thoroughly checked for stability. [Click here](#) to see the mounting details.

3. Insert the shaft on the rotor shaft (The double holes of the shaft should be on the downside, and the single hole should be on the upside.).



4. Mount the bottom flange to the shaft.

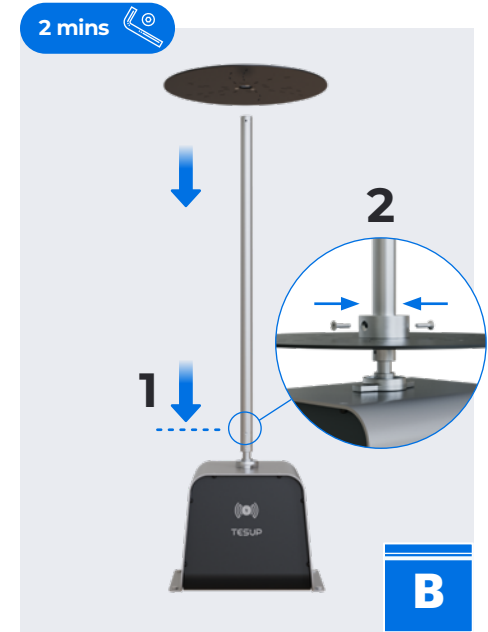

5. Mount the upper bracelet to the shaft.

Make sure of two things: The holes on the bracelet must overlap the holes on the top flange where they will be connected. The holes on the upper flange and the lower flange must also be aligned with each other.



**6.** Insert the turbine blades into the designated housings on the bottom flange, which are marked with the letter “M” for this blade set.

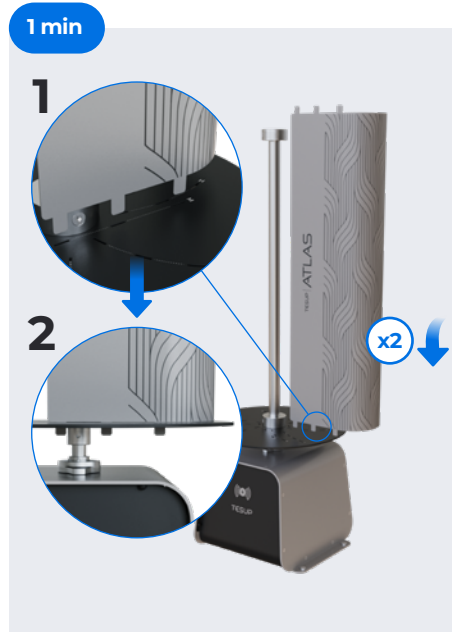

**8.** Carefully bend all the top snaps on the blades using a mallet.

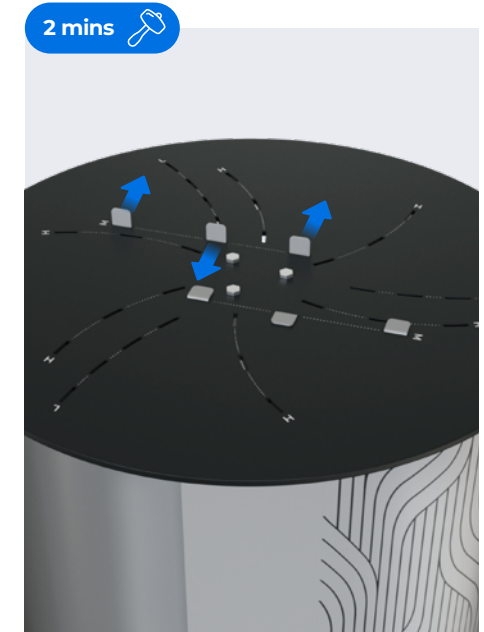

**7.** Insert the top flange and ensure that all the snaps pass through the housings marked with “M” on the top flange. Afterwards mount the top flange to the upper bracelet.



**9.** Turn the upper body upside down. Holding it from both the top and bottom flanges, carefully place the upper body on a flat surface with the top flange facing the floor.



Carefully bend all the bottom snaps on the blades using a mallet.

**10.** Flip the upper body, making sure the top flange is facing up again. Insert the shaft on the rotor shaft.



**11.** Fix the upper body to the base, using the grub screws provided.

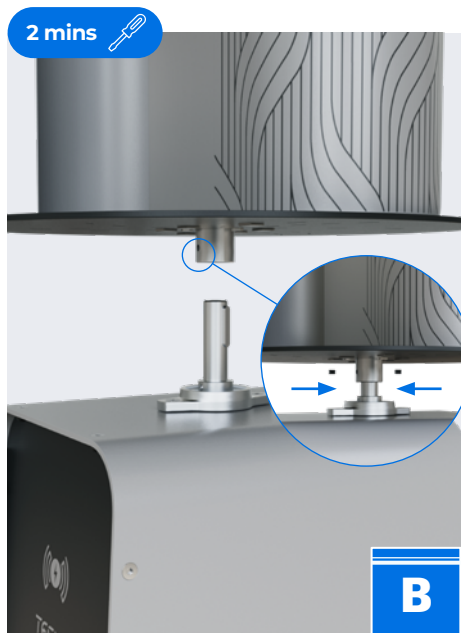

**12.** If there is a battery in the system (in the case of off-grid connections), the maximum voltage value must be manually adjusted either through the “Manage My TESUP” section in the My TESUP App or using the rotary encoder on the body.



**IMPORTANT:** If a short circuit occurs, the turbine will activate its braking system, preventing the blades from turning.



**WARNING:** Incorrect or loose fastening can adversely affect the efficiency of your turbine, potentially causing damage and posing a risk of injury. Ensure that all fasteners are properly tightened.

## ASSEMBLING THE LOW WIND SPEED BLADES

[Click here](#) to watch the ATLAS turbine assembly video.

Fastening packs available in your package and you will be using for this blade set's assembly:



1. Carefully open the packaging, taking care not to damage any of the components. After verifying the shipment for completeness, carefully remove all components from the box.
2. Fix the turbine body to the turbine's final location. Ensure that the mounting base is securely fixed to the mounting surface and thoroughly checked for stability. [Click here](#) to see the mounting details.

3. Fix the shaft to the base using the grub screws provided.



4. Mount the bottom flange to the shaft.

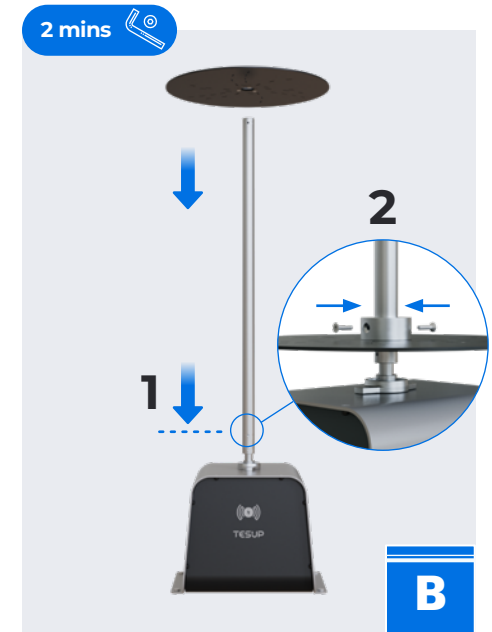

5. Mount the upper bracelet to the shaft.

Make sure of two things: The holes on the bracelet must overlap the holes on the top flange where they will be connected. The holes on the upper flange and the lower flange must also be aligned with each other.



**6.** Bring the upper and lower blades together and take the belt to connect them.

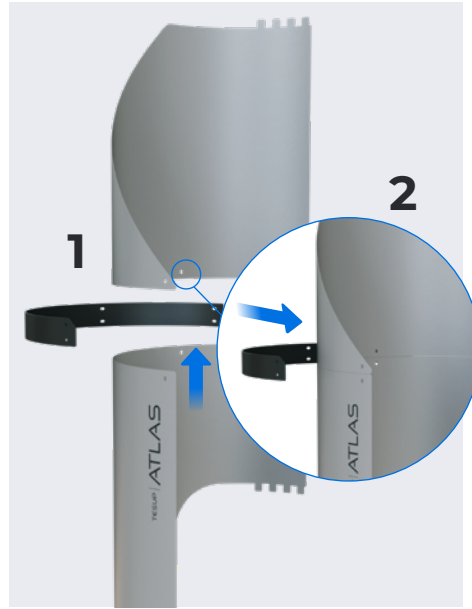

**7.** Mount the upper and lower blades together via the belt. The belt must be fixed to the blades from the outer surface. Repeat these three steps for the remaining blades.



**8.** Insert the turbine blades into the designated housings on the bottom flange, which are marked with the letter "L" for this blade set.



**9.** Insert the top flange and ensure that all the snaps pass through the housings marked with "L" on the top flange. Afterwards mount the top flange to the upper bracelet.



**10.** Carefully bend all the top snaps on the blades using a mallet.

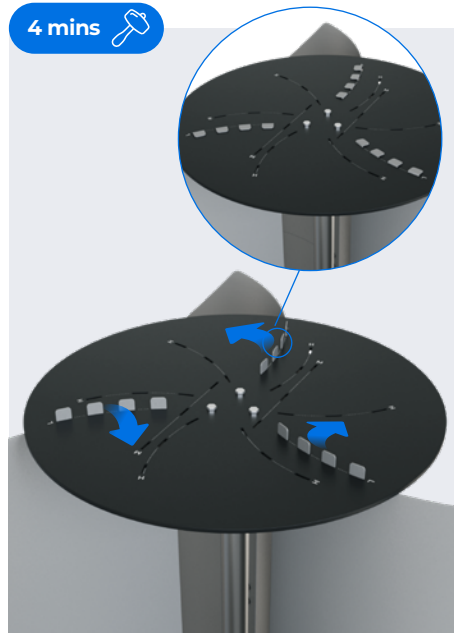

**11.** Carefully bend all the bottom snaps on the blades using a mallet.

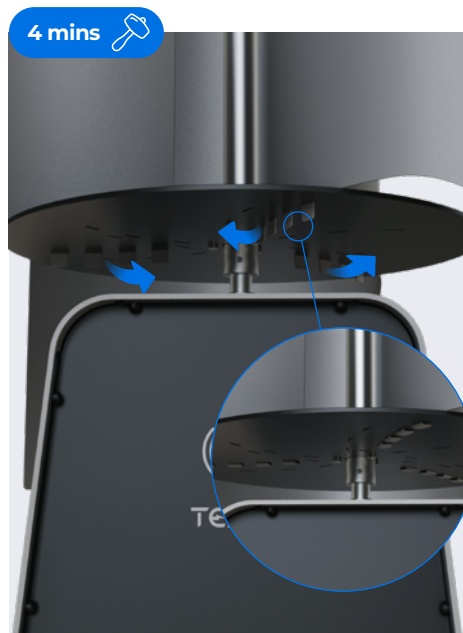

**12.** If there is a battery in the system (in the case of off-grid connections), the maximum voltage value must be manually adjusted either through the “Manage My TESUP” section in the My TESUP App or using the rotary encoder on the body.



**IMPORTANT:** If a short circuit occurs, the turbine will activate its braking system, preventing the blades from turning.



**WARNING:** Incorrect or loose fastening can adversely affect the efficiency of your turbine, potentially causing damage and posing a risk of injury. Ensure that all fasteners are properly tightened.

## WIRING DIAGRAMS

**1. On-Grid Systems:** In this setup, the wind turbine is connected to the grid, allowing for the direct feeding of excess energy into the grid.

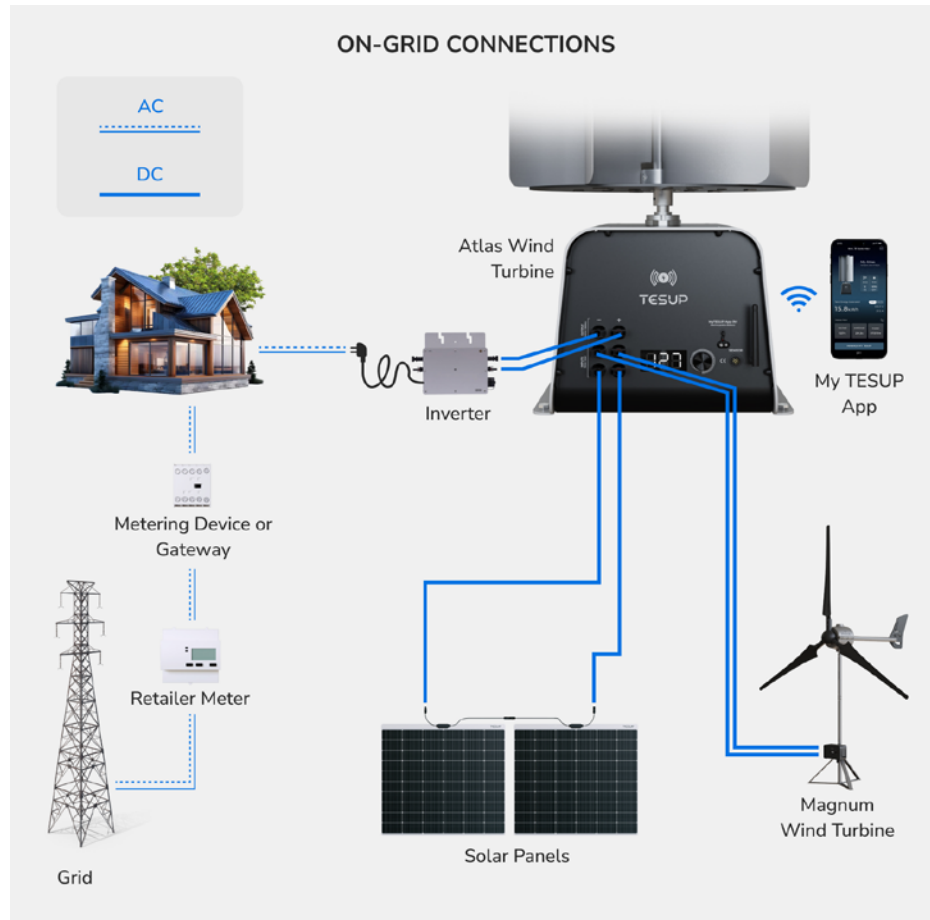

**2. Off-Grid Systems:** This configuration allows for the storage of excess energy generated by the system in batteries for later use.

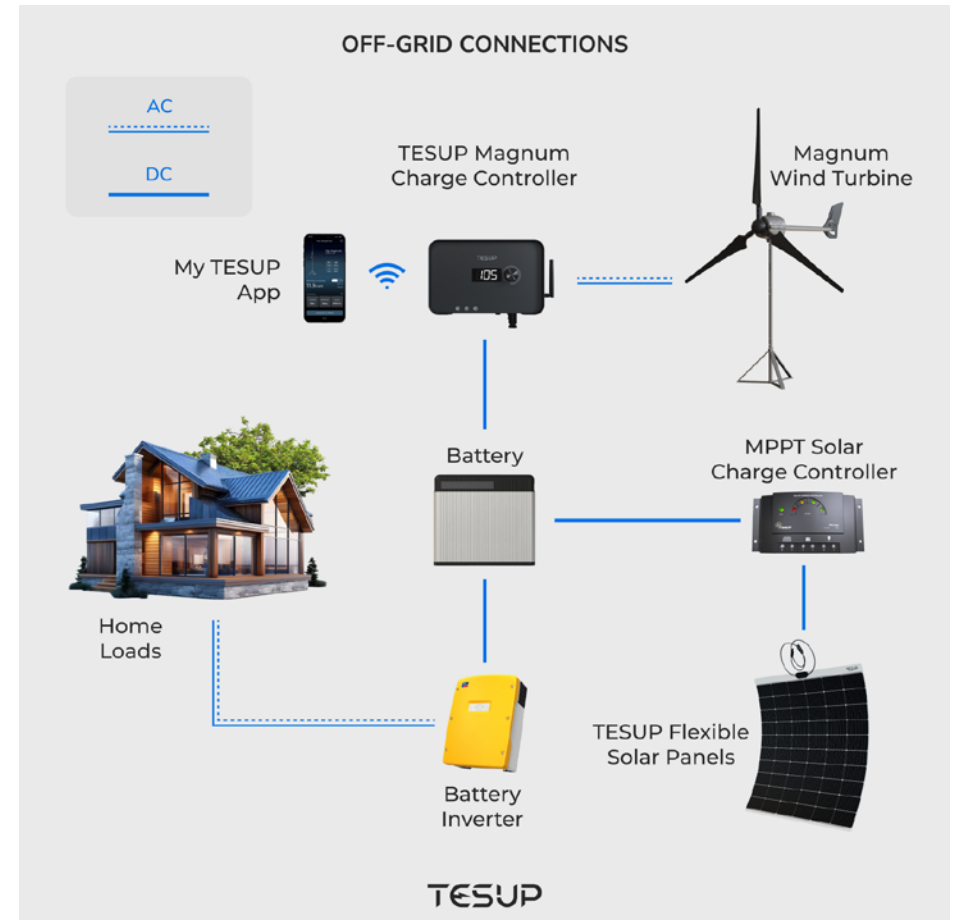

**WARNING:** To operate the system, the TESUP Wind Turbine and the charge controller must be installed outdoors in a dry location.

## My TESUP App

With this app, you can effortlessly monitor the total energy output from all your products over time. By simply scanning the QR code located on your TESUP product, you can remotely control and monitor your TESUP product's operation.



**IMPORTANT:** Your TESUP product must be operational to supply energy to the system during app pairing.



**QUICK TIP:** Your customer account on the TESUP website is not linked to your account in this application. You must first create a separate account.

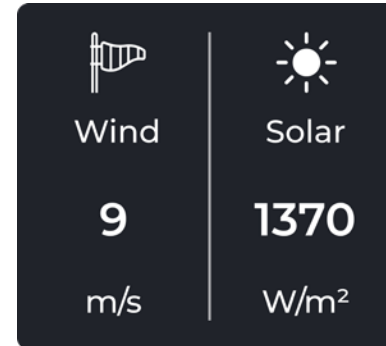

### Track Environmental Data

My TESUP allows you to have real-time access to vital environmental data that directly impacts the efficiency of your TESUP product, such as wind speed and solar irradiance.



**IMPORTANT:** To access wind data, you need an anemometer, which is a wind sensor. TESUP also offers an anemometer as an add-on product upon purchase. You can connect your anemometer to the sensor input on the back of the turbine body.

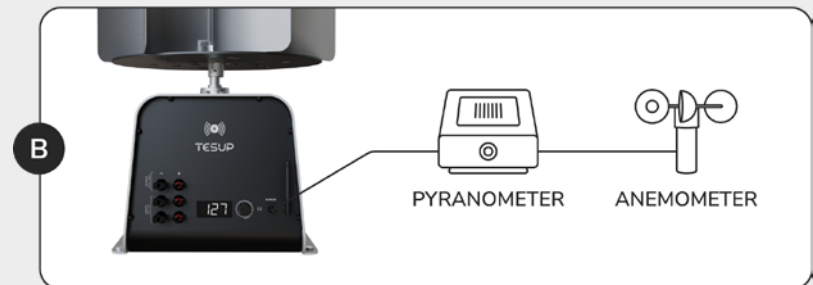
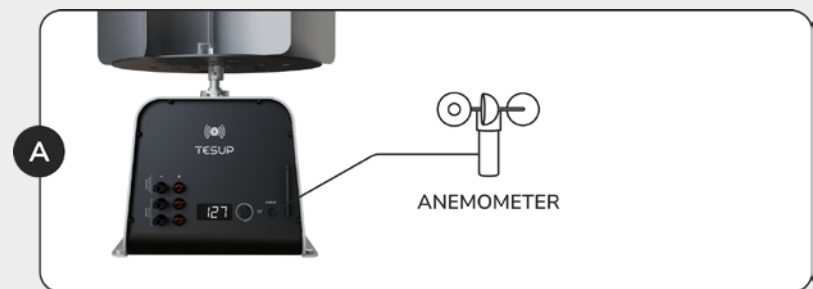

### Real-time Energy Generation Monitoring

My TESUP provides you with up-to-the-minute data on how much energy your assigned products are generating. Whether you're at home, in the office, or on the go, you'll have instant access to the remarkable work being done by your product.

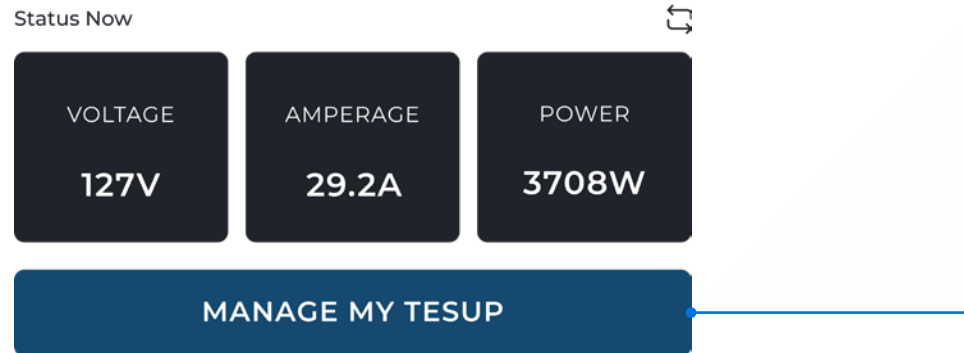

### Adjust Voltage

With this tool you can fine-tune your wind turbine's voltage output to match the specific needs of your energy consumption. By allowing you to make voltage adjustments within a predefined range, this feature ensures that your wind turbine operates at its most efficient, producing just the right amount of energy required.

Your wind turbine operates tirelessly to harness clean energy, but there may be times when you need to halt its operation swiftly and safely. The "Full Brake" function is your tool for precisely that purpose. It offers you the ability to bring your wind turbine to the safest minimum voltage ensuring safety, control, and peace of mind.

### Total Energy Insight, All in One Place

Stay informed about the clean electricity you've generated today, throughout the month, and even access data on average voltage. Use this data to make informed decisions for enhancing your sustainable power generation.

TODAY 30 DAYS

15.0 kWh





# Magnum

Horizontal Axis Wind Turbine

# Magnum

## SYSTEM COMPONENTS

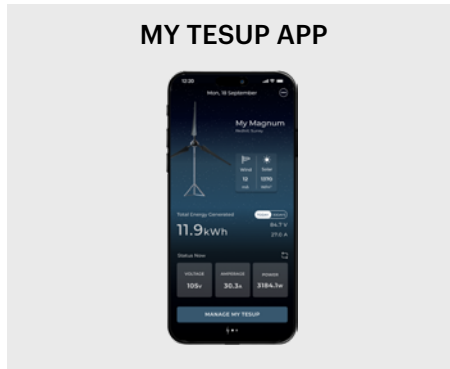

## WIND TURBINE COMPONENTS

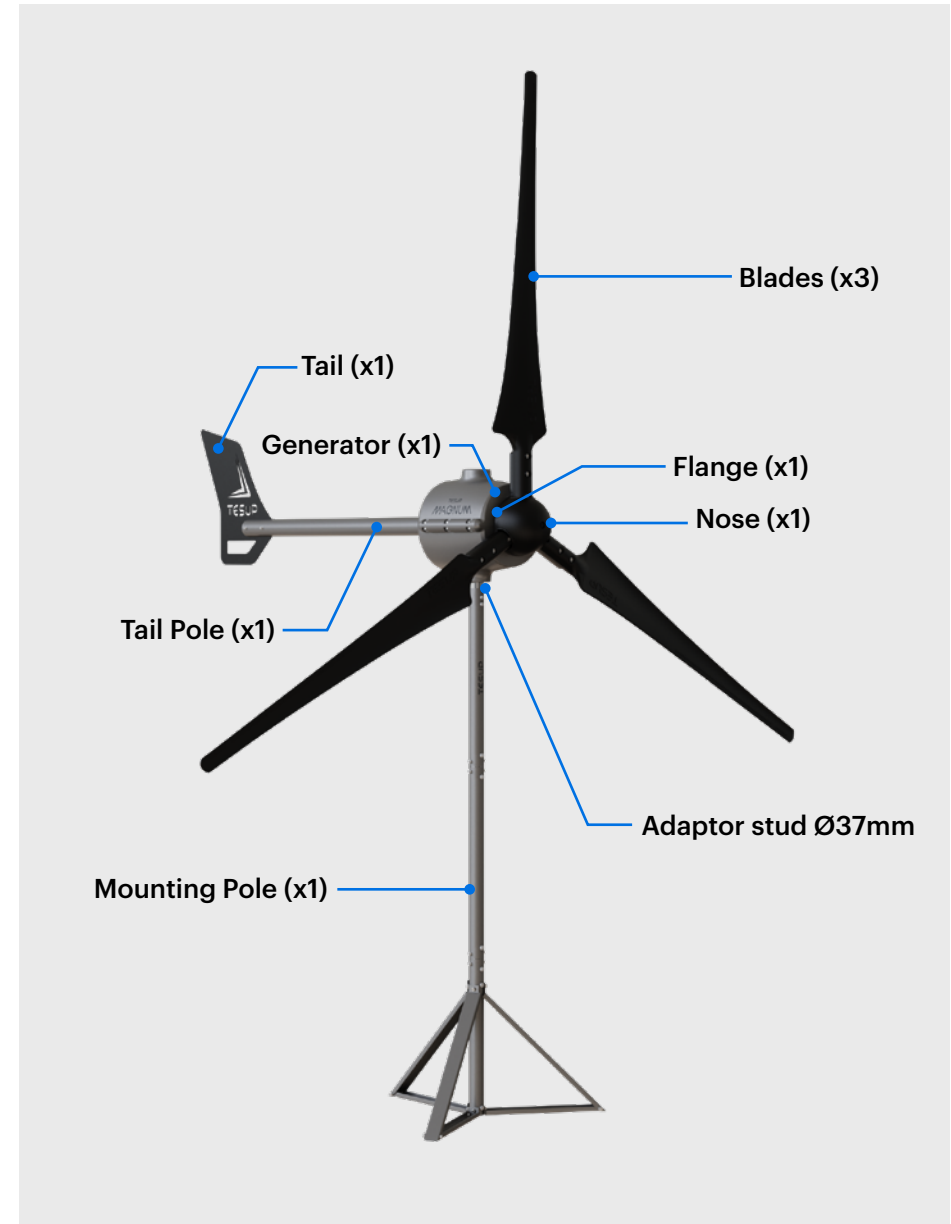

**IMPORTANT:** Please note that the inverter needed for on-grid systems must be supplied separately.

PARAMETER & DIMENSIONAL DETAILS

SPECIFICATIONS	
Designation	Regulated by the Charge Controller
GENERATOR	
Material	Silisium sheetmetal
Type	Permanent magnet generator
Weight	20 kg (44 lbs)
Max. Power	15 kW* nominal motor power, up to 22 kW peak motor capacity <small>*Motor-rated power. Actual wind turbine output varies depending on wind speed, blade set and installation conditions.</small>
Max. RPM	2000
Output voltage	Voltage can be adjusted by the Charge Controller
Direction of Rotation	Both clockwise and counterclockwise
Charge Controller	Included in the box, digital and manual voltage adjusment
Test Standards	EN 61000-6-1 (electromagnetic compatibility – immunity) EN 61000-6-3 (electromagnetic compatibility – emissions)
ROTOR BLADES	
Material	Composite Materials
No. of Blades	3
Diameter	2350 mm (7.71 Feet)
Weight Per Rotor Blades	990 g (2.18 lbs)
Direction Of Rotation	Clockwise
Operational Wind Speed	6 to 35 m/s
Noise	35 dB

POWER CURVE

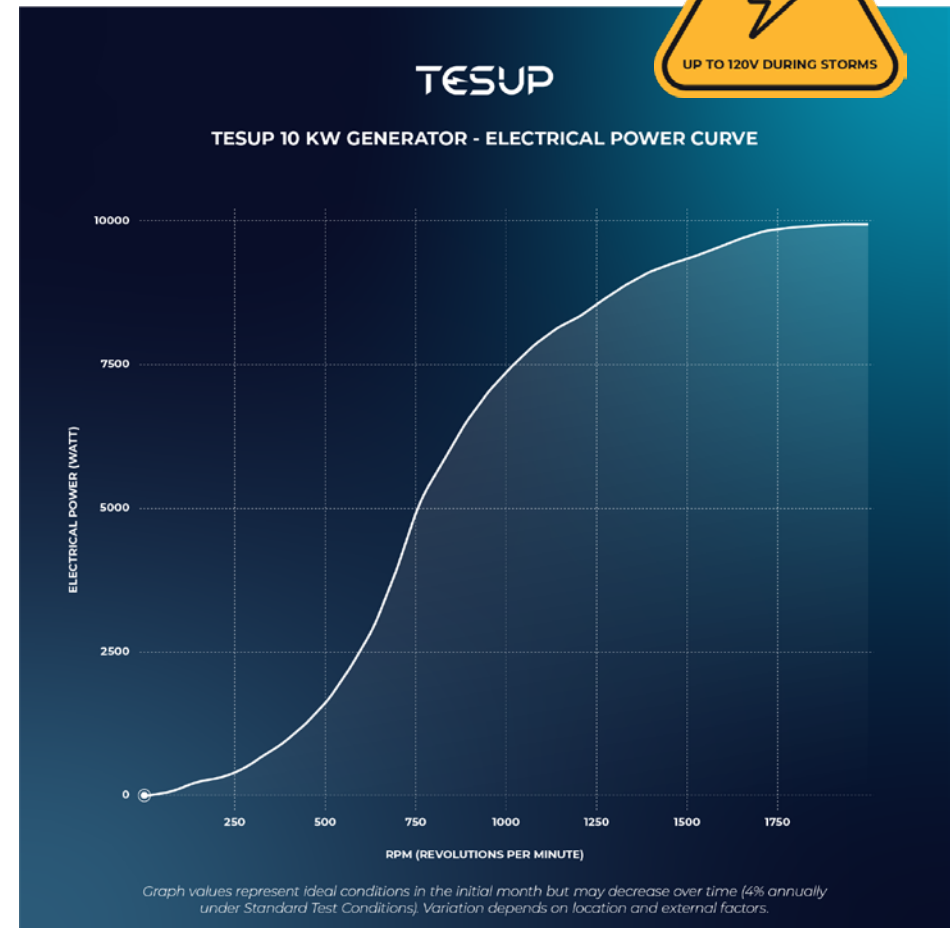

**IMPORTANT:** Humidity, turbulence and the ion levels in the air can impact your turbine’s performance.

## GENERAL ARRANGEMENT AND DIMENSIONS

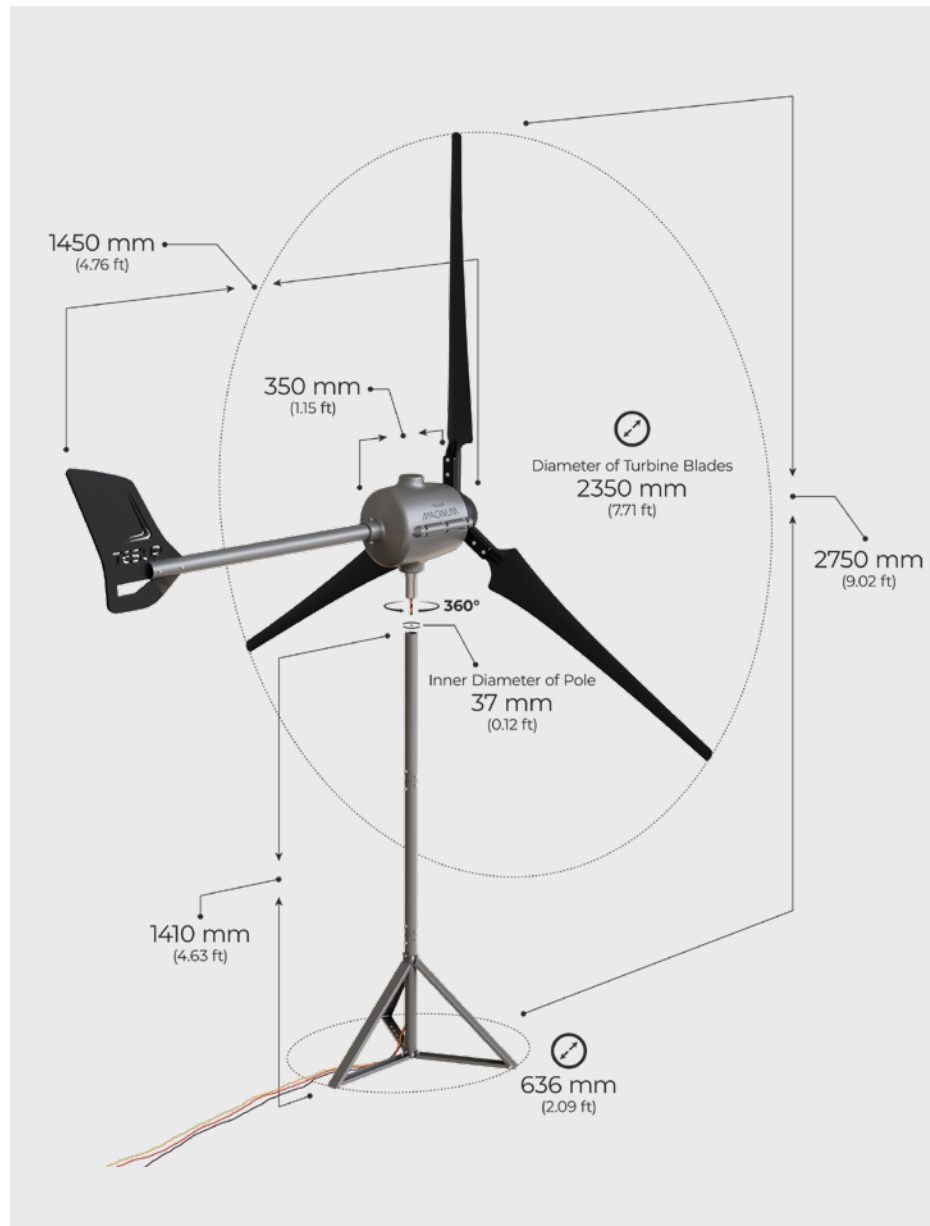

## MOUNTING DETAILS

The mounting surface and bearer selected must be capable of bearing the required load. The size and structure of the foundation should be based on the characteristics of the ground or surface where it will be installed.

The TESUP mounting pole is specifically designed and developed for use with the TESUP wind turbines. To ensure technical and safety compliance, we strongly recommend using the TESUP mounting pole exclusively with the TESUP wind turbine. The use of other types of poles or supports may lead to safety issues and result in the voiding of your warranty.

[Click here](#) to watch the Mounting Pole Assembly video.



**QUICK TIP:** It is recommended to consult with a qualified structural engineer for advice on determining the optimal mounting surface.



**WARNING:** Before proceeding with wind turbine installation, ensure that the mounting pole is securely fixed to the mounting surface and thoroughly checked for stability.

# Mounting Pole Installation

## MOUNTING POLE COMPONENTS

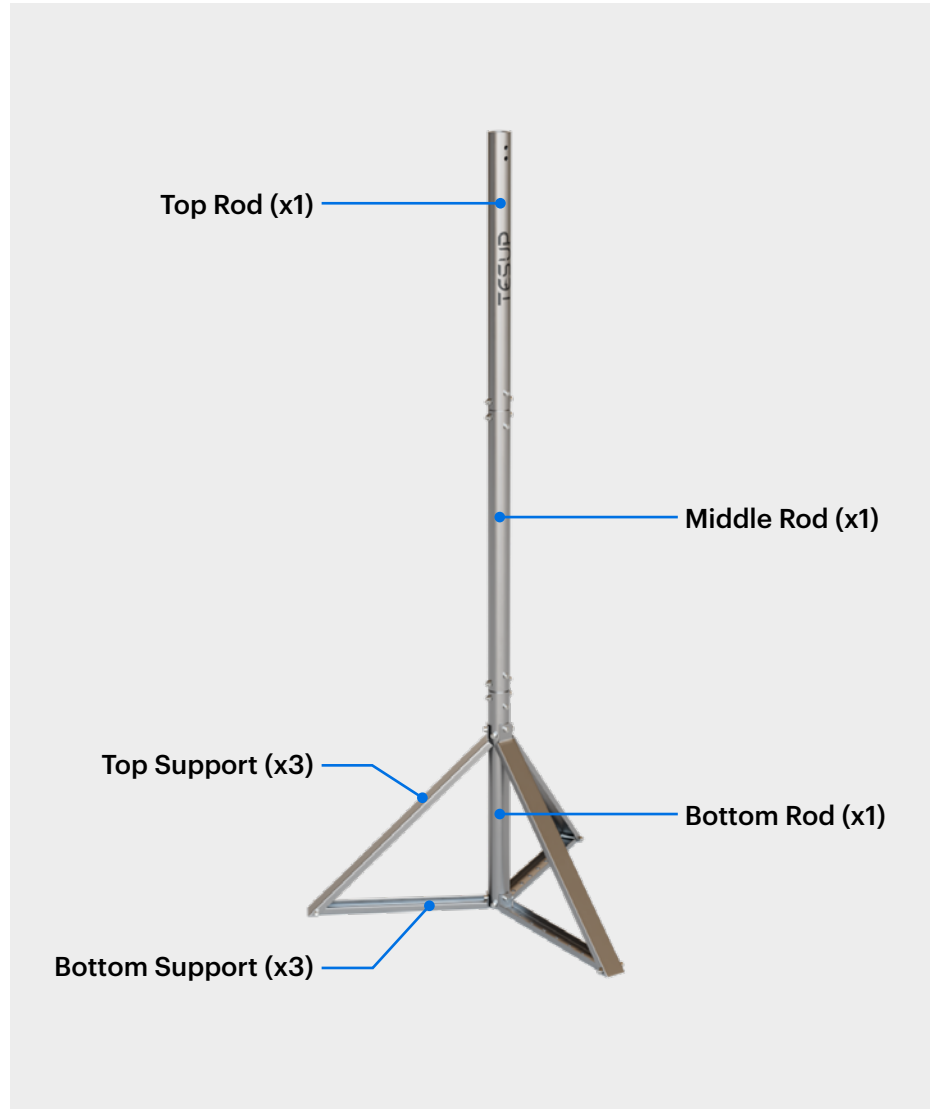

## GENERAL ARRANGEMENT AND DIMENSIONS

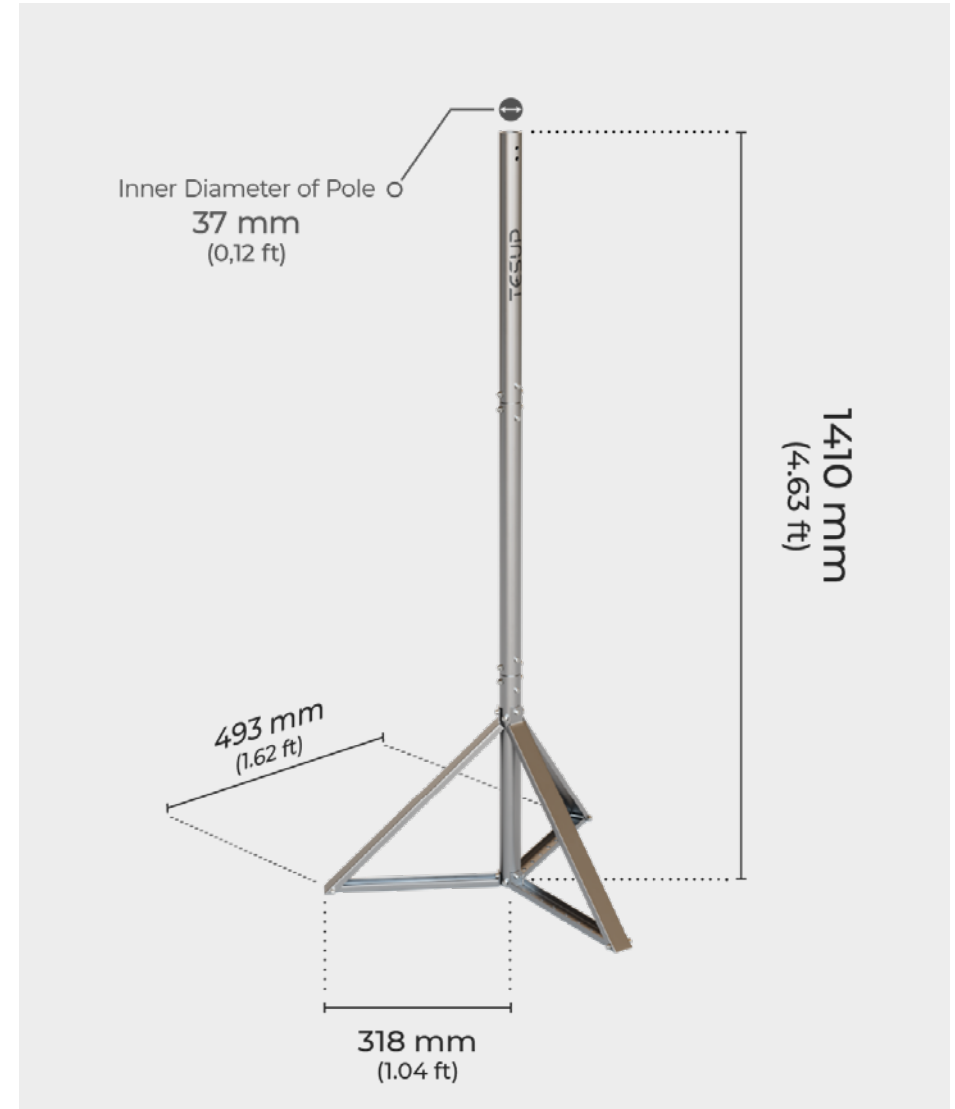

**QUICK NOTE BEFORE MOUNTING POLE ASSEMBLY**

Before beginning the mounting pole installation, please group the parts by referring to the diagrammatic drawings below to avoid errors.

The top and bottom supports should be assembled together based on the number of notches on them. The number of notches corresponds to the holes on the bottom rod. For instance, parts with 2 notches should be aligned with the holes numbered 2 in the figures below.

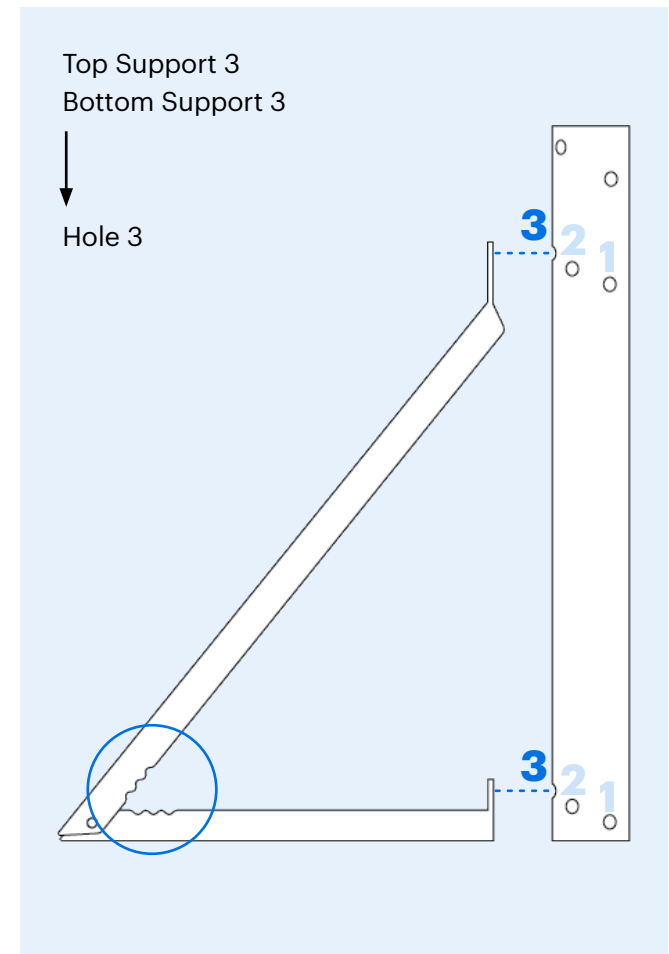
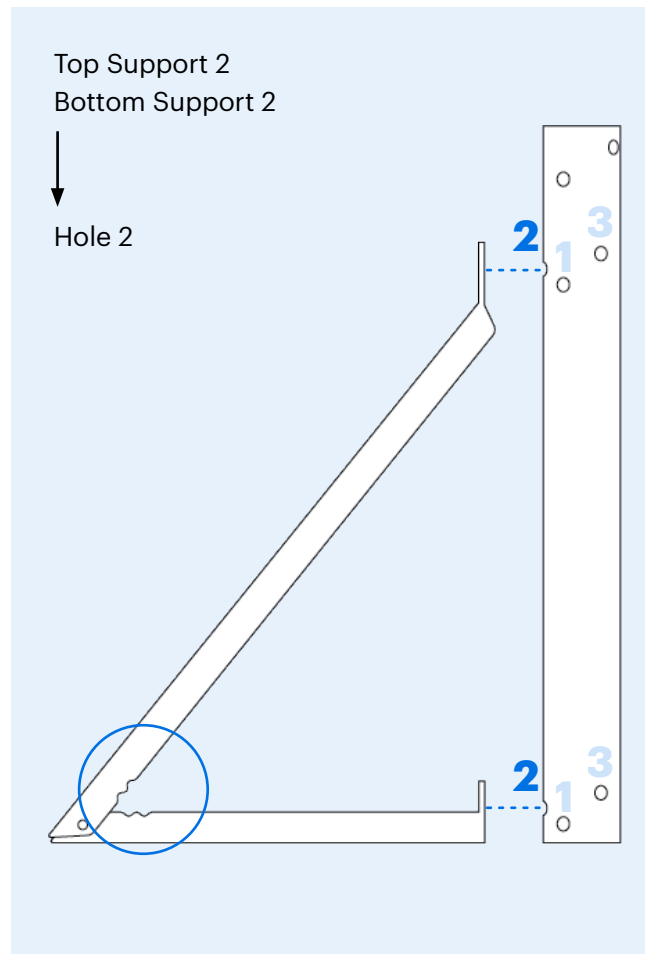
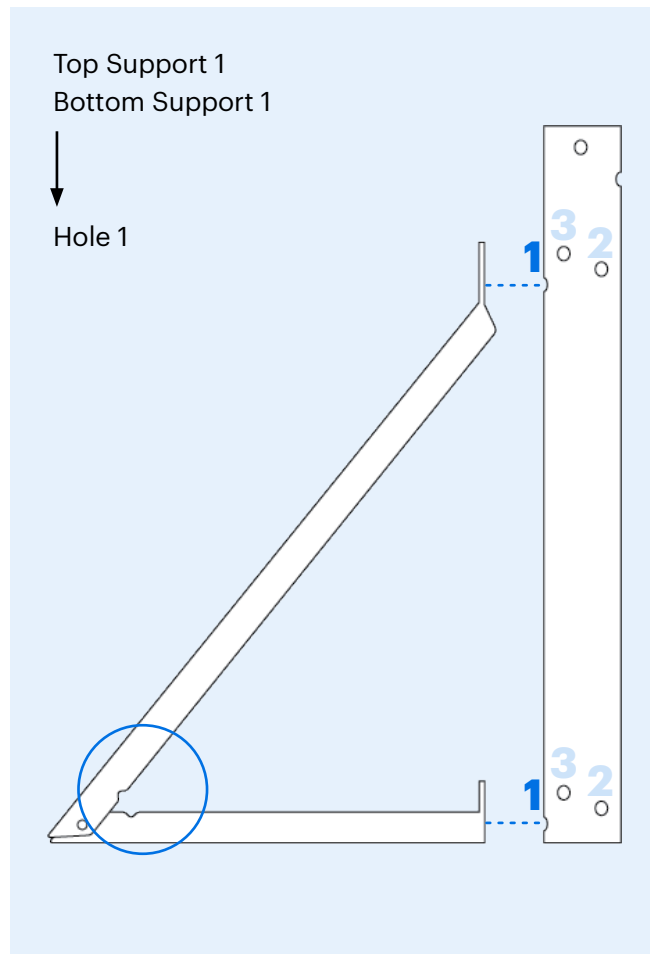

## ASSEMBLING THE MOUNTING POLE

[Click here](#) to watch the Mounting Pole Assembly video.

Fastening packs available in your package and you will be using for this product's assembly:

**MP**

**1.** Carefully open the packaging, taking care not to damage any of the components. After verifying the shipment for completeness, carefully remove all components from the box.



**WARNING:** It is recommended to choose a day with calm weather conditions and low wind speed to install the mounting pole.

**2.** Assemble the 3 bottom supports, bringing them together to attach them securely to the bottom rod.



**3.** Attach the bottom supports to the bottom rod, using the fasteners provided.

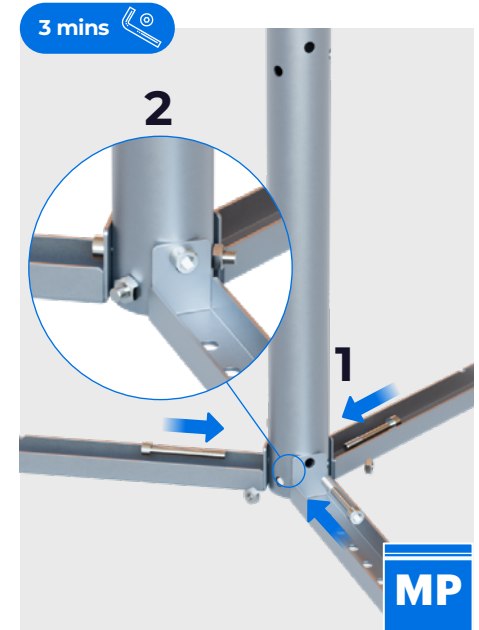

**4.** Using the relevant tools, secure the unit to the ground by fastening it through the first and last holes on the bottom supports.

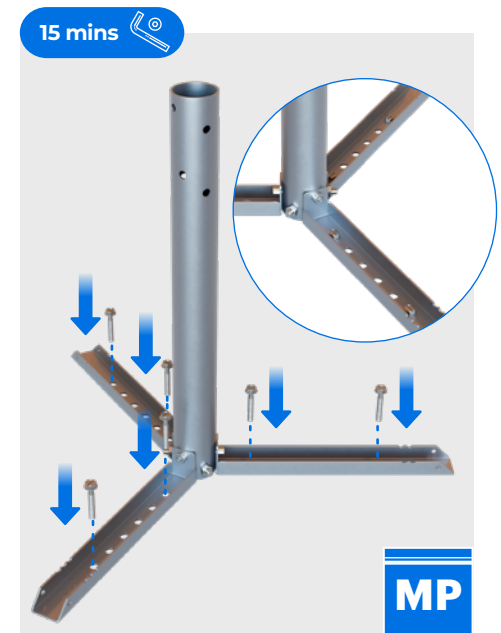

**5.** Attach the top support to the bottom support on one side, and to the bottom rod hinge on another.

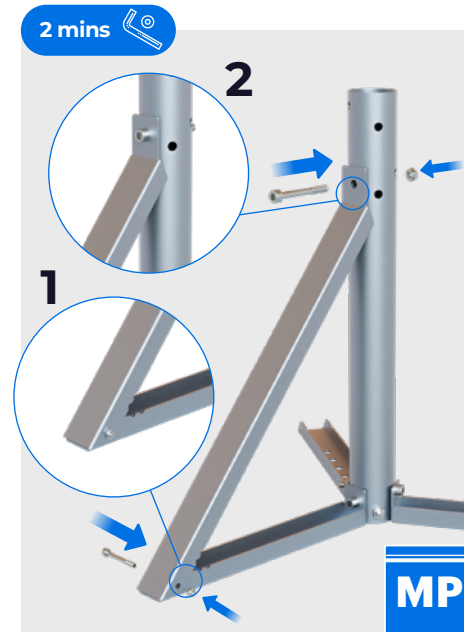

**6.** Repeat step 5 for the remaining two top supports.



**7.** Insert the interconnecting pipe onto the bottom rod.

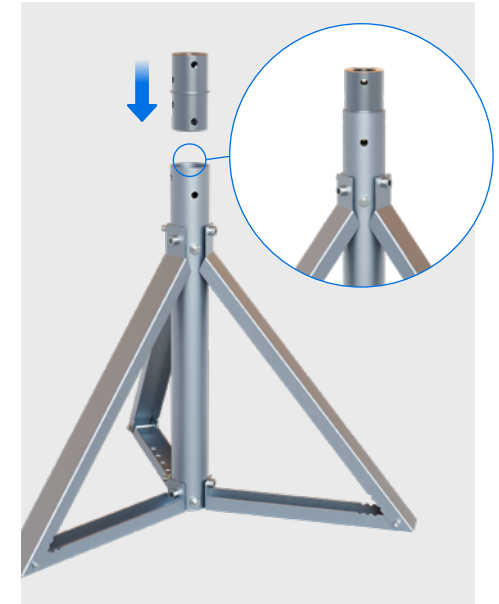

**8.** Fix the interconnecting pipe to the bottom rod with the help of the fasteners provided.



**9.** Insert the middle rod onto the bottom rod and the interconnecting pipe.

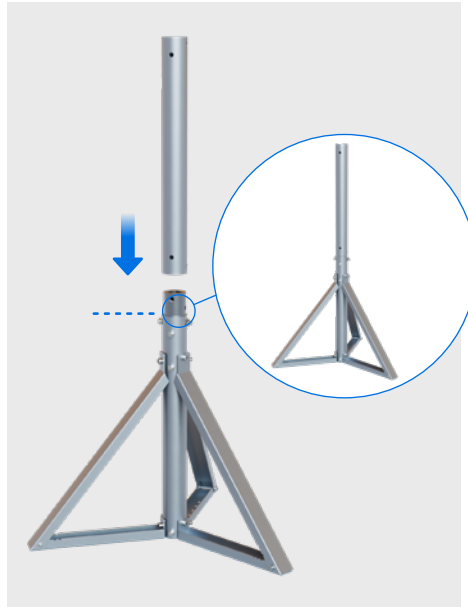

**11.** Insert and mount the top rod by repeating the previous steps.

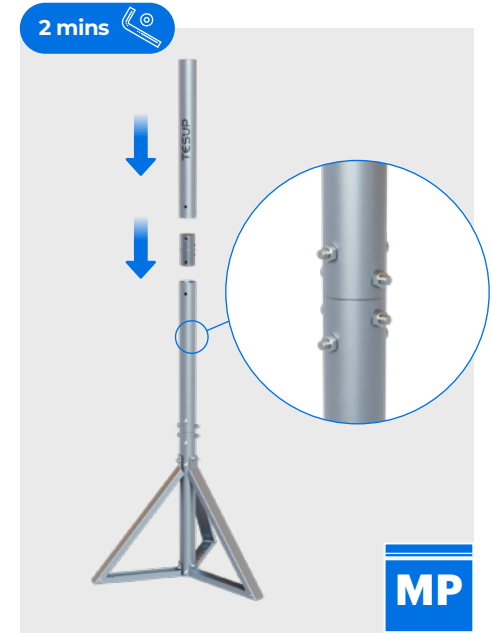

**10.** Fix the middle rod to the interconnecting pipe with the help of the fasteners provided.

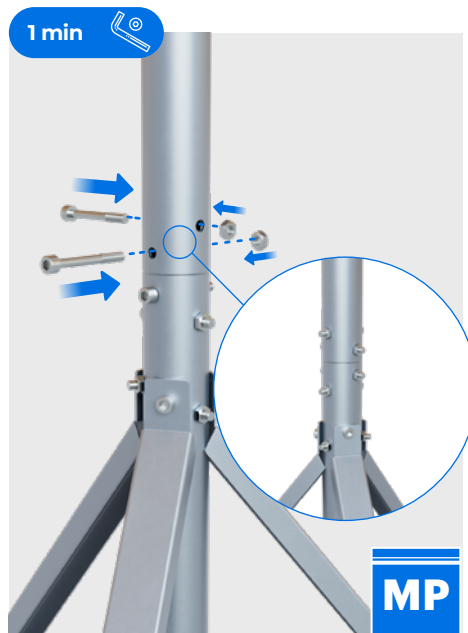

## ASSEMBLING THE WIND TURBINE

[Click here](#) to watch the MAGNUM turbine assembly video.

Fastening packs available in your package and you will be using for this product's assembly:



**1.** Carefully open the packaging, taking care not to damage any of the components. After verifying the shipment for completeness, carefully remove all components from the box.

**2.** Follow the instructions to complete the installation of the [mounting pole \(MP\)](#).



**WARNING:** The mounting pole must be securely fixed to the mounting surface and thoroughly checked for stability before proceeding with the wind turbine installation.

**3.** Connect your cable, which will be used to link the wind turbine and the charge controller, to the 3-phase AC output cables at the wind turbine output. Ensure that the connections are properly electrically insulated.

**4.** Pass the cables you added through the mounting pole (MP), and pull them through the cable outlet.



**5.** After passing the cables through the outlet, position your MAGNUM wind turbine onto the mounting pole (MP) and securely tighten the fixing screws on the mast.



**6.** Insert the tail pole into its designated slot and attach it to the generator.

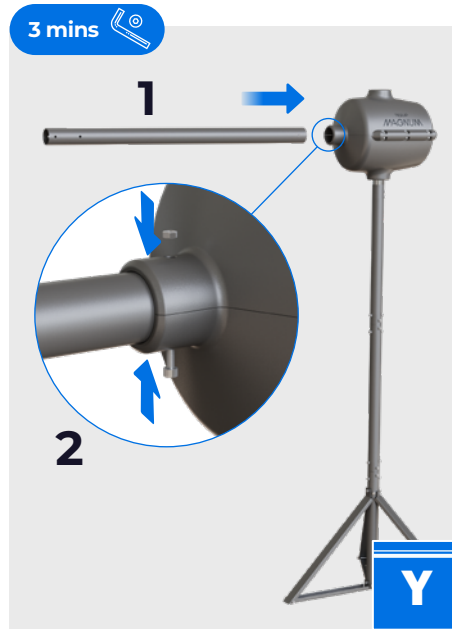

**8.** Follow the instructions to attach and secure the tip and back components of the blades, then place the fixed blades on the flange in any order and screw them correctly.

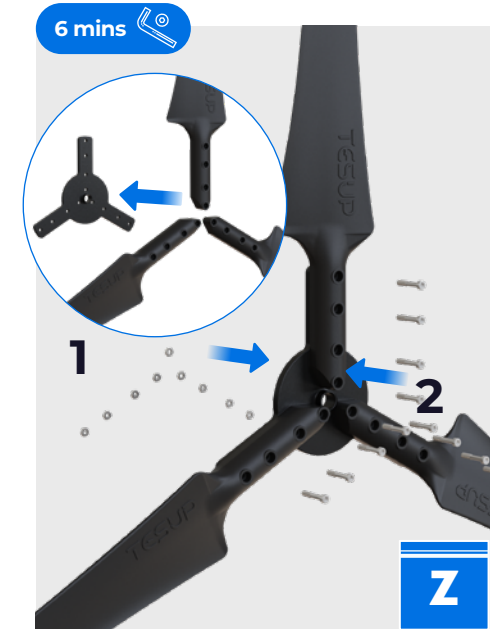

**7.** Place the tail plate into its designated slot at the end of the tail pole and tighten it by screwing it correctly.

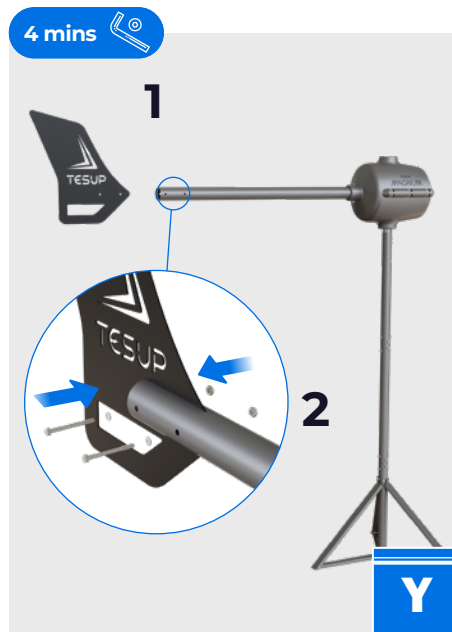

**9.** Attach the fixed unit to the generator.

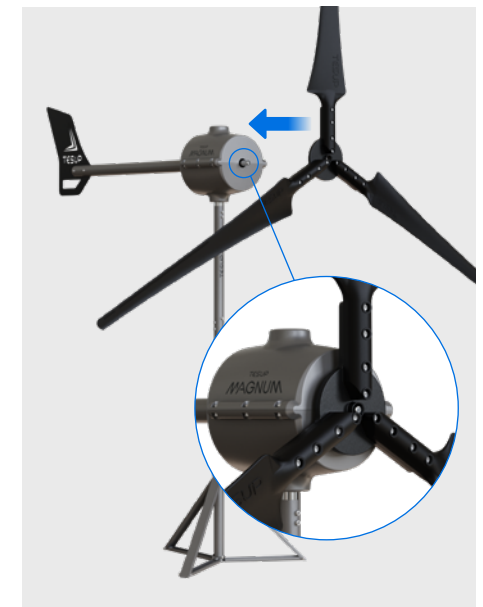

10. Place the nose on the flange as instructed.

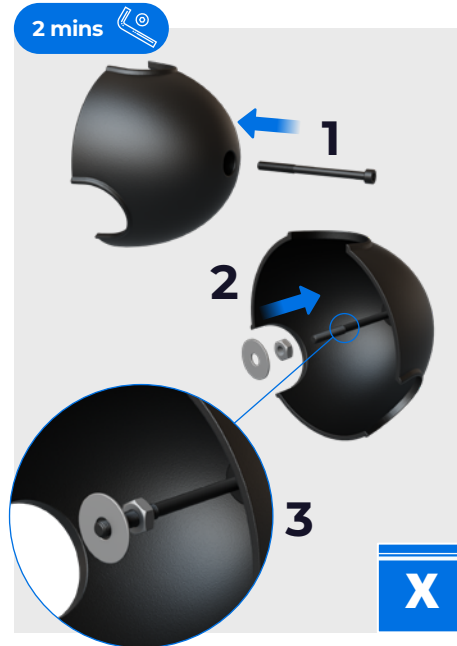

11. Secure the entire unit to the generator by screwing it through the nose.



12. Connect the 3-phase AC output terminals located at the wind turbine output to the charge control unit with battery-inverter input, ensuring tight screw connections.

13. If you are using your charge control unit in 'Battery' mode, adjust the maximum voltage using the potentiometer on the unit. (The maximum voltage setting is important for system protection and activating the automatic braking system when the wind speed reaches the capacity to produce the predetermined voltage value.)



**IMPORTANT:** Before proceeding, if you are using a charge control unit, ensure that a battery-inverter is installed in it.



**IMPORTANT:** If a short circuit occurs, the turbine will activate its braking system, preventing the blades from turning.



**WARNING:** Incorrect or loose fastening can adversely affect the efficiency of your turbine, potentially causing damage and posing a risk of injury. Ensure that all fasteners are properly tightened.

## Charge Controller

The Wind Turbine Charge Controller from TESUP is an intelligent IoT-integrated device which controls the wind turbine. It safely and efficiently charges and controls your battery with the wind generator combination.

With its discreet appearance and simple operation with integrated protection functions, this device has high efficiency and no-load losses. The version of the controller will significantly increase the life and sustainability of all the component of the system.

The special features of TESUP Charge Controller and product information are listed below:

- Use of solid-state components.
- Manual brake function.
- Integrated IoT function. Ability to control the turbine's energy generation via MyTESUP App.
- Increasing the life of the controller. Microprocessor controlled charge with integrated voltage and current limiting.
- Dump-load is included. Modern Load dissipation system in three steps to avoid immediate blockage of turbine.

### PARAMETER DETAILS

Recommended max. battery charging voltage levels are as follows:

SPECIFICATIONS		
12 V	24 V	48 V
13.8 - 14.2 Volts	27 - 28.4 Volts	52 - 58 Volts



## CHARGE CONTROLLER COMPONENTS



## GENERAL ARRANGEMENT AND DIMENSIONS



## WIRING DIAGRAMS

**1. On-Grid Systems:** In this setup, the wind turbine is connected to the grid, allowing for the direct feeding of excess energy into the grid.

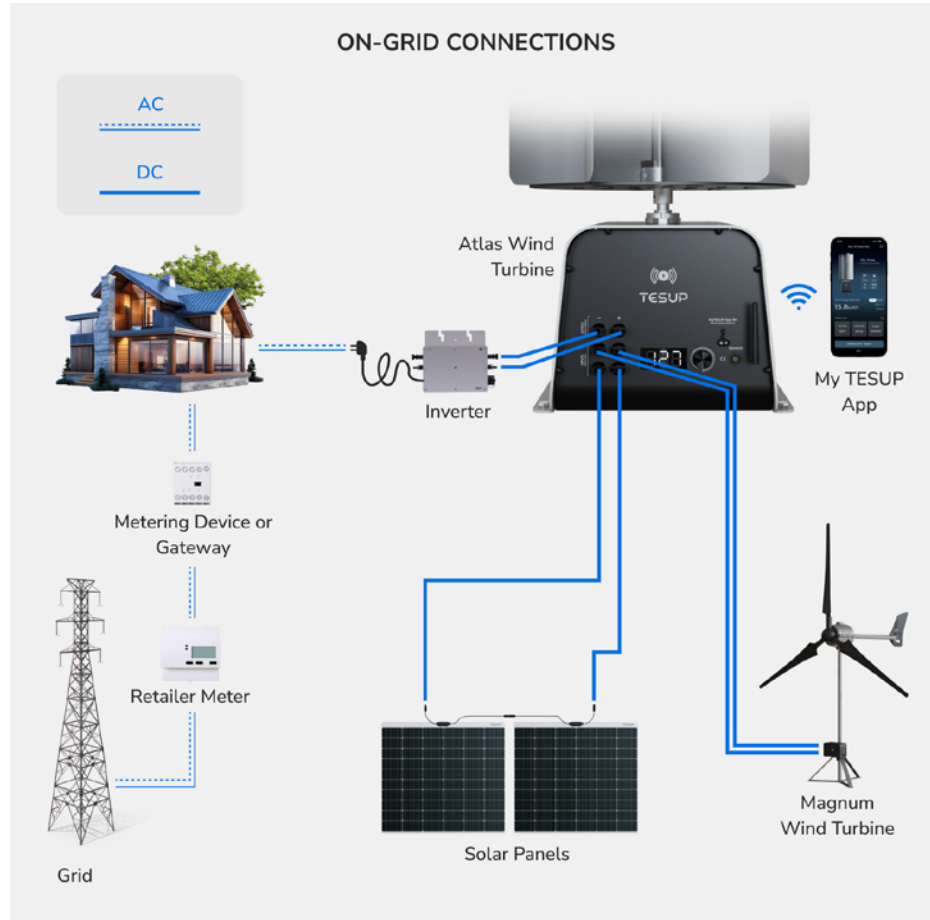

**2. Off-Grid Systems:** This configuration allows for the storage of excess energy generated by the system in batteries for later use.

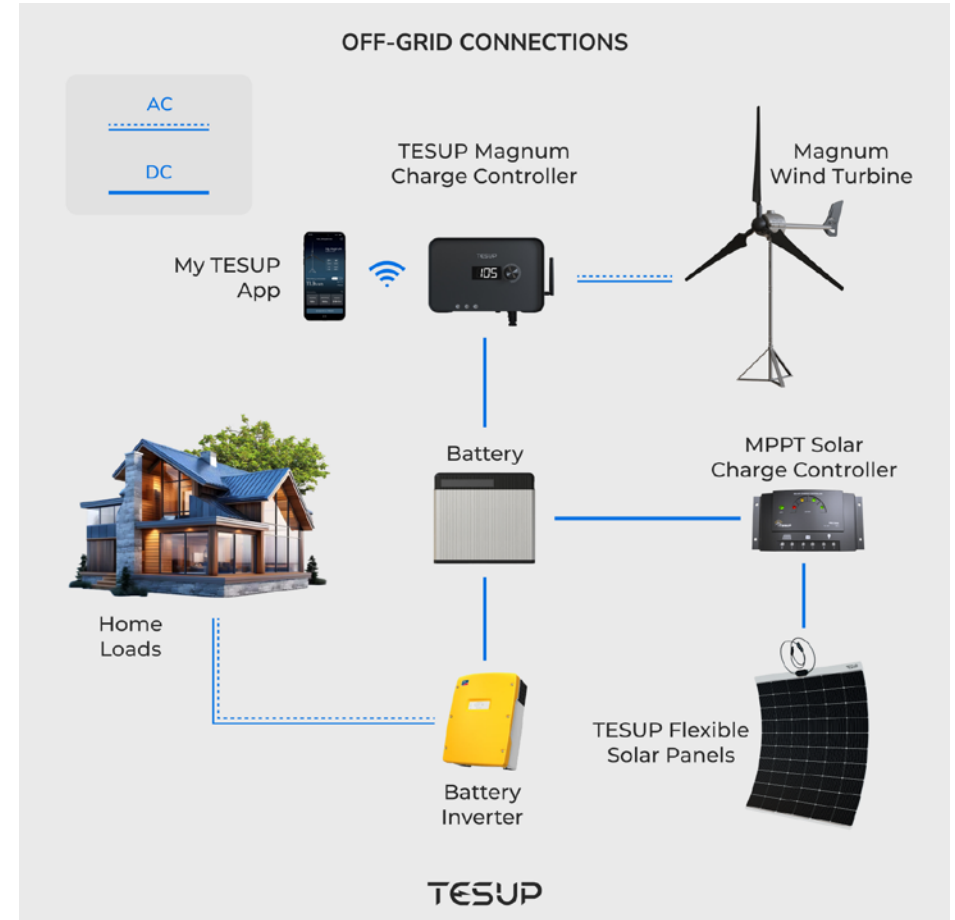

**WARNING:** To operate the system, the TESUP Wind Turbine and the charge controller must be installed outdoors in a dry location.

## CONNECTING YOUR WIND TURBINE TO THE CHARGE CONTROLLER

To connect the cables of the wind turbine to the charge controller, follow these steps:

1. Strip the wire coming through the turbine and the connecting wires.
2. Secure the wires with a wire nut and wrap electrical tape around each wire.
3. Insert the wire into the controller and then tighten the screw. Repeat this step for the remaining wires.
4. When connecting directly to batteries, or to an inverter for AC power, insert the wire into the appropriate connectors, ensuring to match the positive and negative indicators.
5. Connect the DC output to the inverter using connection cables with MC4 connectors. Ensure proper polarity by paying attention to the positive (+) and negative (-) connection points.
6. Finally, connect the AC power cable.



**IMPORTANT:** Wind turbine is turned on once the brake is switched off.



**WARNING:** Exercise caution when connecting wind turbines to charge controllers. Ensure proper alignment and secure attachment of cables, wires, and connectors for efficient operation.

## MY TESUP APP

With this app, you can effortlessly monitor the total energy output from all your products over time. By simply scanning the QR code located on your TESUP product, you can remotely control and monitor your TESUP product's operation, as well as accessing environmental data such as wind speed and solar irradiance.



**IMPORTANT:** To access wind data, you need an anemometer, which is a wind sensor. TESUP also offers an anemometer as an add-on product upon purchase. You can connect your anemometer to the sensor input on the back of the turbine body.

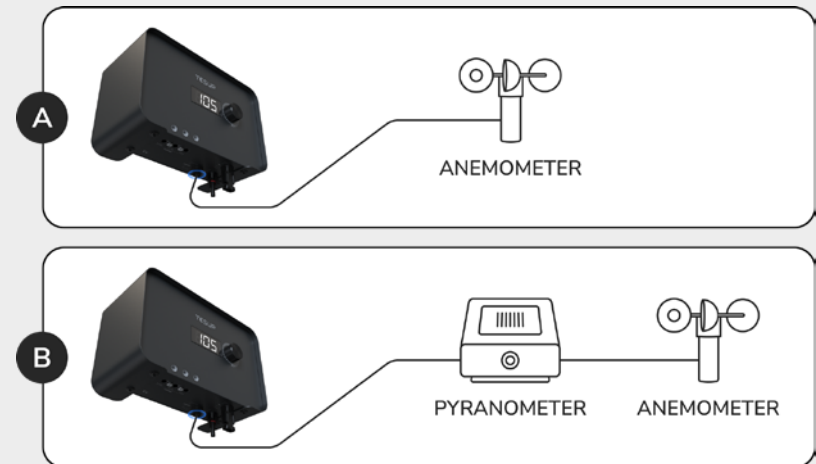

## Declaration Of Conformity

TESUP

### Declaration of Conformity



**Manufacturer:** TESUP GLOBAL AS  
22 Sutton Lane, North Chiswick, London W4 4LD, United Kingdom

#### PRODUCTS

**Product Type:** Wind Turbine

**Model Name:** Atlas, Magnum, V7, H7, Atlas X7, HERA, Magnum 5, Atlas 7, Master X

**This declaration of conformity is issued under the sole responsibility of the manufacturer TESUP GLOBAL AS.**

The equipment of the declaration is described above is in conformity with the relevant Union harmonization legislation:

1. 2006/42/EC Directive 2006/42/EC OF THE European Parliament and of the Council of 17 May 2006 on machinery and amending Directive 95/16/EC (recast) (1).
2. 2014/30/EU DIRECTIVE OF THE EUROPEAN PARLIAMENT AND OF THE COUNCIL of 26 February 2014 on the harmonization of the laws of the Member States relating to electromagnetic compatibility (recast).
3. 2014/35/EU OF THE EUROPEAN PARLIAMENT AND OF THE COUNCIL of 26 February 2014 on the harmonization of the laws of the Member States relating to the making available on the market of electrical equipment designed for use within certain voltage limits (recast).

Used harmonized standards and other standards:

1. EN ISO 12100: 2011-03 Safety of machinery – General principles for design – Risk assessment and risk reduction
2. EN 61400-2:2014 Wind turbines - Part 2: Small wind turbines

TESUP

### Declaration of Conformity



**Manufacturer:** TESUP GLOBAL AS  
22 Sutton Lane, North Chiswick, London W4 4LD, United Kingdom

#### PRODUCTS

**Product Type:** Wind Turbine

**Model Name:** Atlas, Magnum, V7, H7, Atlas X7, HERA, Magnum 5, Atlas 7, Master X

These products as described above are in conformity with the relevant UK designated legislation and statutory instruments (and their amendments):

1. SI 2016 No 145: Electromagnetic Compatibility Regulations 2016
2. SI 2016 No 1101: Electrical Equipment (Safety) Regulations 2016
3. SI 2008 No 1597: Supply of Machinery (Safety) Regulations 2008

References to the relevant designated standards used or references to the technical specifications in relation to which conformity is declared:

1. BS EN ISO 12100:2010 Safety of machinery – General principles for design – Risk assessment and risk reduction
2. BS EN 61400-2:2014 Wind turbines - Part 2: Small wind turbines

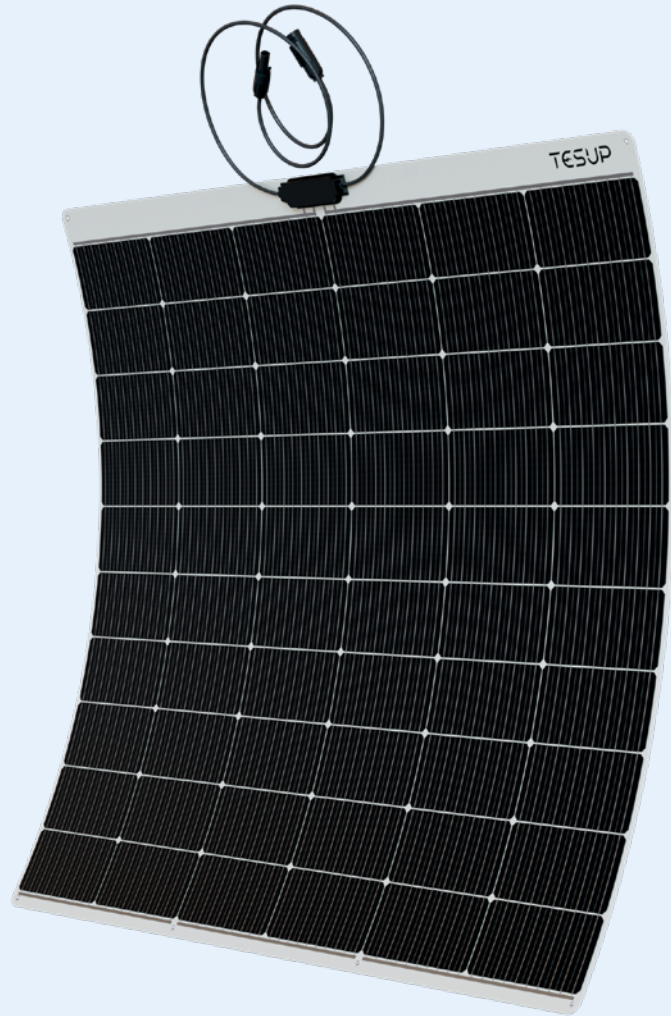

Product Manuals

# Flex Solar Panel

# Flex Solar Panel

## Important Safety Instructions

- **All TESUP products are for outdoor use only.**
- Read and understand all safety precautions before installing, wiring, or maintaining the solar panel. As exposure to sunlight or other light sources can generate current, it's advisable to have the installation performed by an experienced solar panel installer.
- Please follow the grounding techniques as specified in the NEC (National Electrical Code).
- Install solar panel system in accordance with this manual and local and national building codes. Failure to comply may affect and possibly void your warranty.
- This Flexible Solar Panel has limited flexibility and is not highly flexible.
- Flexing and bending can cause micro cracks in the cell circuit resulting in premature failure, in these circumstances the warranty provided with this product will be void.
- Please wear soft-soled shoes when walking on the solar panel, although we kindly suggest avoiding it whenever possible.
- Do not touch the terminal box or the ends of the output cables (connectors) with bare hands when in sunlight, regardless of whether the PV module is connected to or disconnected from the system.
- Do not connect or disconnect modules while they are exposed to light or external power sources such as a battery. Disconnecting under load can lead to arcing and damage to the connector.



**WARNING:** Avoid shorting the leads. If inadvertent shorting occurs, cover the panel with opaque material to block all light before attempting cable disconnection.



**WARNING:** Fire Resistant Cables Only



**WARNING:** Do not install or handle the modules when they are wet or during periods of high wind.



**WARNING:** High voltage may be present when modules are interconnected in series. High currents may be present when modules are connected in parallel.



**WARNING:** The solar panel surface can reach high temperatures under the sun. Be careful when touching.



**WARNING:** If the foil on the product is torn, the product becomes unusable and poses a risk of electric shock.



**IMPORTANT:** TESUP flexible modules can be walked on when firmly mounted on a smooth, rigid surface with no irregularities. Use soft-soled shoes; avoid heels and shoes with rigid soles. Do not step on uninstalled modules or modules in removable installations.

## PERSONNEL REQUIREMENTS

All work on the solar panel systems must be carried out by authorised individuals. These individuals must have a comprehensive understanding of the safety devices and regulations before undertaking any work.

Authorised personnel are defined as follows:

Operating mode	Necessary qualifications
Normal operation	Trained personnel
Cleaning	Trained personnel
Maintenance	Suitably trained persons
Repair	Manufacturer



**WARNING:** To prevent electric shock, fire, and injury, do not touch terminals while a panel is exposed. Use suitable guards, such as insulated tools and gloves, to avoid direct contact with the solar panel output terminals.

## MODIFICATIONS BY THE USER

To ensure compliance with the Low Voltage Directive (LVD) (2014/35/EU), it is essential that only original TESUP product components are used and the solar panel system is properly erected. The use of components from other manufacturers or any modifications or changes made by the user is strictly prohibited. Such actions could invalidate the declaration of conformity.

## RESIDUAL RISKS

The user manuals in this book includes relevant sections that describe any residual risks that may arise during operation or maintenance of the solar panel system.

## General Instructions

Before you begin installing your solar panel system, read the entire user manual section of this book. Following the instructions and recommendations in this manual section will help assure safe and enjoyable use of your new renewable energy system. Please take the time to read through this manual prior to installation.

- TESUP reserves the right to modify its products, technical specifications, and these installation instructions without prior notice.
- Please be aware that your solar system generates electric current.
- These guidelines are specific to flexible modules. Please read and follow the instructions carefully, including all safety recommendations.
- Never open the junction box on the back of the photovoltaic module. Opening the junction box and photovoltaic module and modifications will void your warranty.
- The installation techniques, handling, and use of this product are beyond company control. Therefore, TESUP assumes no responsibility for loss, damage or expense resulting from improper installation, handling, or use.
- Adhere to proper grounding techniques as established by the National Electrical Code.
- The module contains no user-serviceable parts; do not attempt repairs.
- Installation should be carried out exclusively by qualified personnel.
- Avoid standing on, dropping, scratching, or allowing objects to fall on the modules to prevent potential damage and warranty voidance.
- Avoid placing objects on the modules to prevent potential damage or staining of the surface.

- If the front sheet or the back sheet is torn, contact with any module surface or module frame can cause electric shock.
- Do not install or handle the modules when they are wet or during periods of high wind.
- Do not allow water to pool on or near the module.
- Retain these instructions for future reference.
- Do not use different types or models of solar modules in the same system.
- Do not cut or pierce the module, this might cause live components to be exposed and/or damage the module.
- Do not bend or apply excessive force to the cables.
- Installation, maintenance and removal of photovoltaic modules must take place on dry surfaces.
- Use tools with insulated grips only.
- Do not use photovoltaic modules near flammable or explosive substances.
- Keep the modules in their original packaging until the moment of their installation. Do not use damaged photovoltaic modules (damaged during transport or installation).
- Please do not apply any protections, paint or varnish to the modules.
- Do not drop heavy or sharp items onto the modules.
- Do not concentrate sunlight (e.g. mirrors or lenses) or other sources of artificial light on the modules.

- Do not dismantle or remove any part or label affixed by the manufacturer.
- Avoid installing modules in locations where they may be submerged in water for lengthy periods.



**WARNING:** Flexing and bending cause micro cracks in the cell circuit resulting in premature failure. In these circumstances the warranty provided with this product will be void.

### PRODUCT FEEDBACK

Please notify the manufacturer or their authorised representative about any of the following:

- Accidents
- Potential safety hazards associated with the solar panel system
- Uncertainties arising from the translation of the original instructions
- Description of the solar panel system

### OPERATING & INSTALLING CONDITIONS

Please make sure that:

- The system has been erected correctly by a suitably trained person.
- All operating personnel have read and fully understood the translation of the original instructions.
- The system is properly maintained and repaired.

## INTENDED USE

- Install or use TESUP solar panel system for its intended use only.
- Observance of the original instructions and compliance with the maintenance and repair instructions are essential preconditions of use for the intended purpose.

## REASONABLY FORESEEABLE MISUSE

Follow the recommended guidelines for optimal performance and safety. Deviating from these guidelines may release the manufacturer from liability for any resulting damages.

- For your best protection and peace of mind, please note that the manufacturer cannot be held responsible for damages resulting from equipment alterations or improper handling during assembly, installation, start-up, operation, maintenance, or repair.
- For peak performance and reliability, use only manufacturer-supplied original parts and accessories. Non-approved parts may lack proper testing and could lead to reliability issues. The manufacturer is not liable for damages resulting from non-approved parts or accessories.
- Reasonably foreseeable misuse includes:
  - Operating the system outside the manufacturer's specified parameters.
  - Making modifications or changes to the solar panel system without obtaining written approval from the manufacturer.
  - Using non-original parts that are not recommended by the manufacturer.
  - Operating the system in water.

By adhering to the manufacturer's guidelines, you can safeguard your solar panel system and enjoy its benefits for years to come.

## Storage & Operation

### STORAGE

**Ambient temperature:**  
-35 to +30°C

**Storage location:**  
Dry, frost-free

### OPERATION

**Ambient temperature:**  
-35 to +30°C

This product generates electrical current when its front side is exposed to light. Even though the voltage and current from a single module are low, touching the terminals or wiring can result in electric shock or burns. These risks significantly increase when multiple modules are installed together, generating higher voltages and currents that can be dangerous and potentially lethal. TESUP will not be liable for any accidents, damage, or injuries, including electric shock, arising from incorrect use or installation.

To minimise risk, always turn the front of the module away from the sun or any intense light source during wiring. Alternatively, cover the front side during installation. Do not use different types or models of solar modules in the same system.

- Do not modify the electrical connections of the modules, including opening or removing the junction box.
- Avoid cutting or piercing the module to prevent potential exposure of live components or damage.
- Do not bend or apply excessive force to the cables.
- Installation, maintenance, and removal of photovoltaic modules must take place on dry surfaces.
- Use tools with insulated grips only.

- Do not use photovoltaic modules near flammable or explosive substances.
- Keep the modules in their original packaging until the moment of their installation. Do not use damaged photovoltaic modules (damaged during transport or installation).
- Do not apply any protections, paint, or varnish to the modules.
- Do not drop heavy or sharp items onto the modules.
- Do not concentrate sunlight (e.g., mirrors or lenses) or other sources of artificial light on the modules.
- Do not dismantle or remove any part or label affixed by the manufacturer.
- Do not install modules in locations where they may be submerged in water for lengthy periods.

The Company (TESUP) is not responsible for modifications and external damages that may inhibit voltage generation. While we take utmost care to ensure that product descriptions, pictures, information, and prices are correct, we do not accept any liability for any inaccuracies, errors or omissions. We do not accept any liability for any inaccuracies for incorrect usage of TESUP products. We do not take any responsibility for installation and modifications mistakes for the products which are delivered disassembled. Colors may differ slightly from those shown on the website due to limitations of internet, software, and computer hardware technologies. In line with our policy of continuous product improvement, TESUP reserves the right to change, vary or make different the product specification without prior notification.



## Technical Details

### SYSTEM COMPONENTS

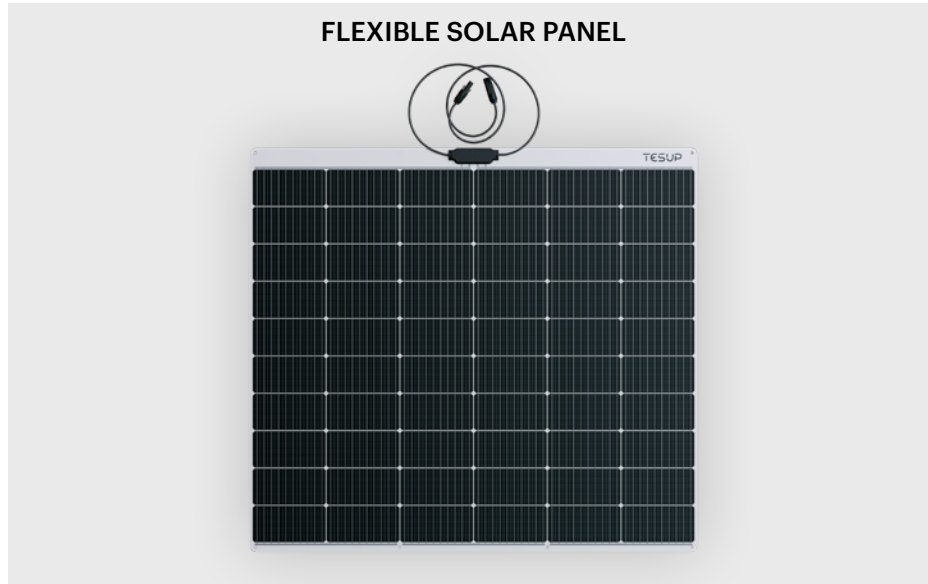

**IMPORTANT:** Please note that the inverter needed for on-grid systems must be supplied separately.

### SOLAR PANEL COMPONENTS

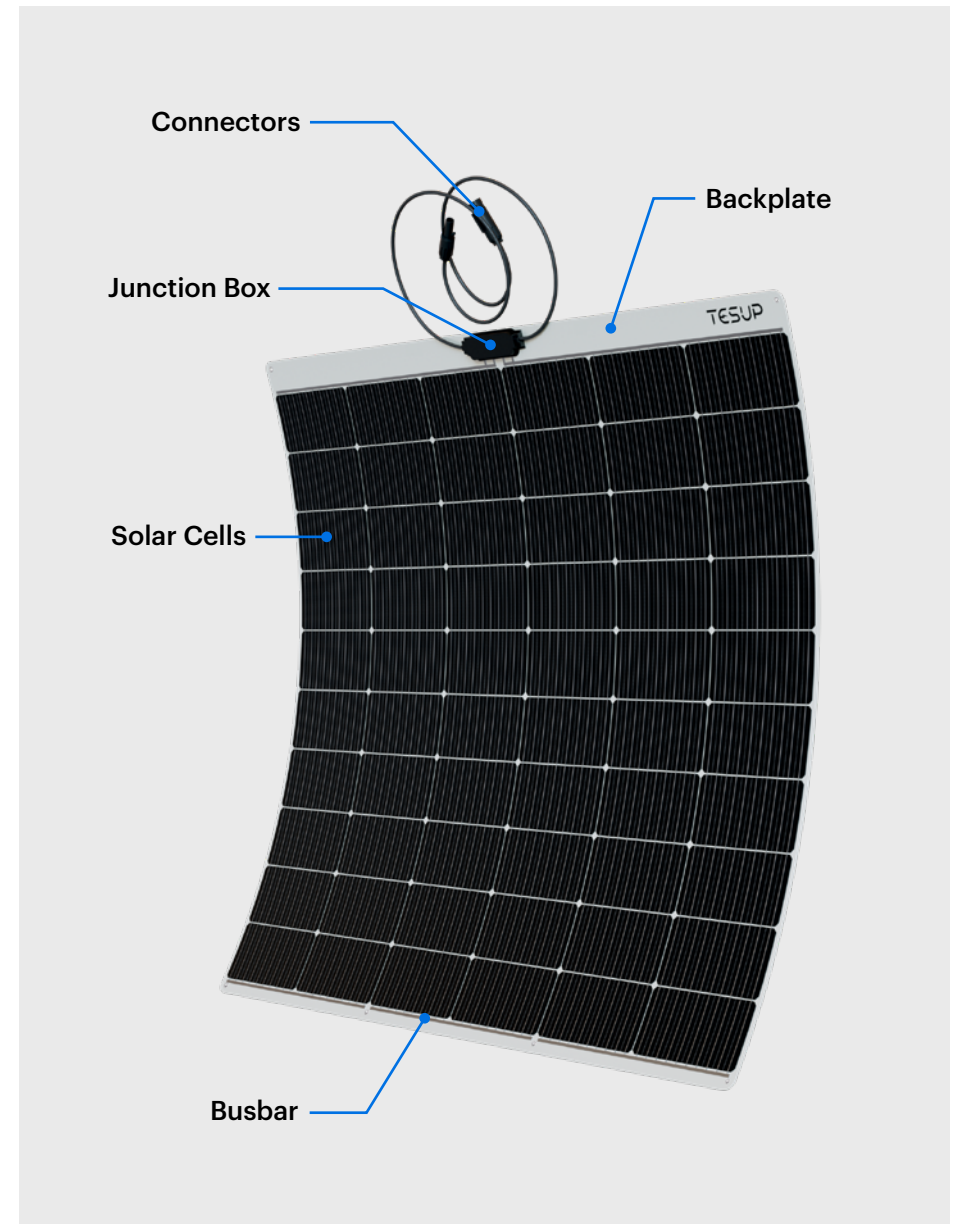

PARAMETER & DIMENSIONAL DETAILS

SPECIFICATIONS	
Type	230 W Flexible Solar Panel
Rated Max. Power (Pmax)	230 W
Current	Direct Current
Current at Pmax	6.94 A
Voltage at Pmax	33.15 V
Short Circuit Current	7.4 A
Open-Circuit Voltage	40.6 V
Nominal Operating Cell Temp.	-35 to +30 °C
Recommended Minimum Solar Irradiance	30 W/m <sup>2</sup>
Weight	5.8 kg (12.8 lbs)
Dimensions	1115 x 1005 x 1.49 mm (3.66 x 3.30 x 0.0049 ft)



**IMPORTANT:** In off-grid connections, solar charge controllers are required to safely connect your solar panel to the battery. If your inverter is not equipped with a charge controller with MPPT technology, we strongly recommend charge controllers.

CURRENT - VOLTAGE CURVE

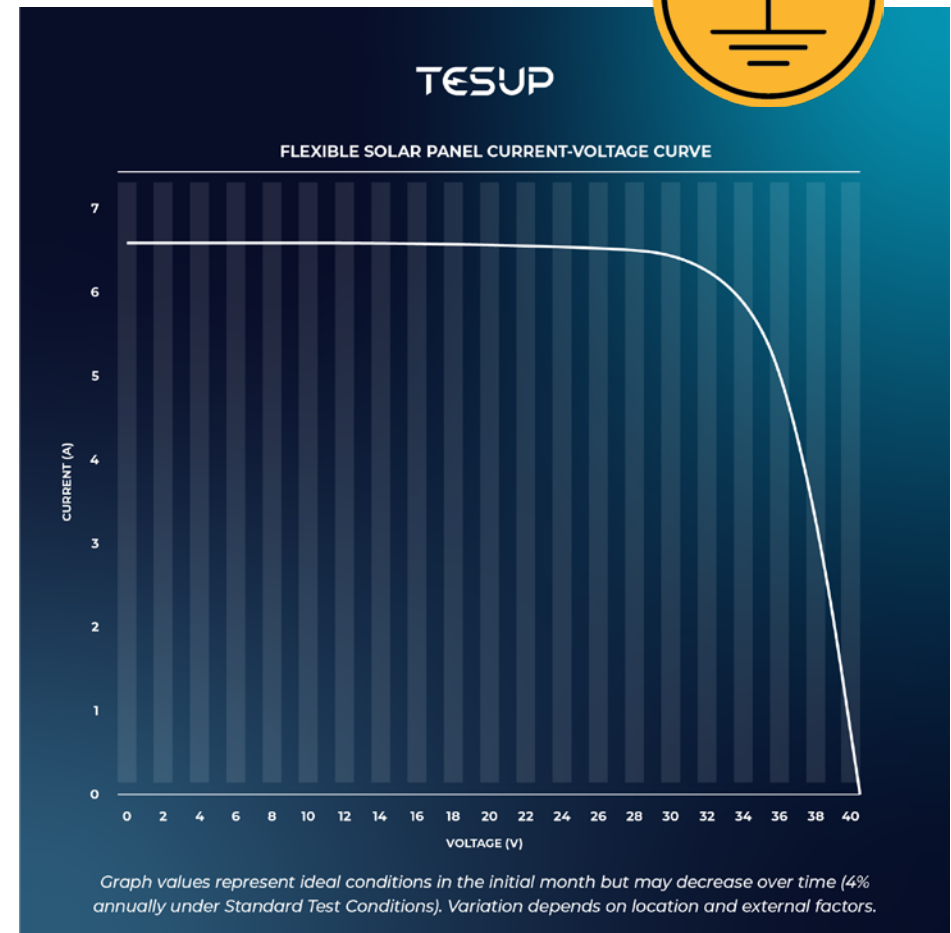

**WARNING:** Avoid shade, as even a small amount of shade will reduce power output. Ensure that the sun will be able to shine on the module even on the shortest day of the year.

## GENERAL ARRANGEMENT AND DIMENSIONS

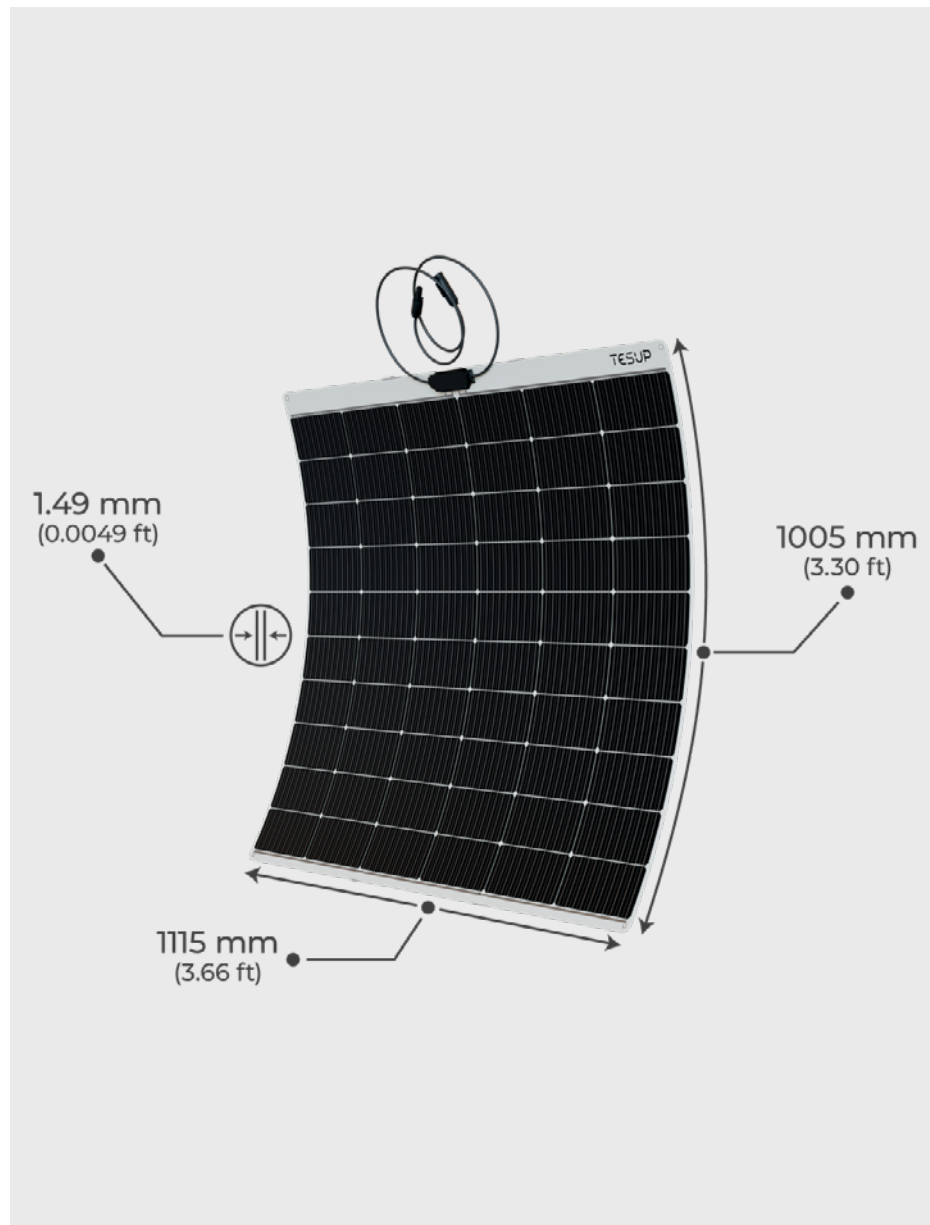

## Module Mounting

TESUP warranty for flexible solar panel is contingent upon modules being mounted in accordance with the requirements described in this section.

Care should be taken to provide ventilation behind or underneath the modules, especially in hot environments. In cold environments of less than 0°C, care should be taken to avoid flexing of the panel or impact to the panel.

To prevent water from entering the junction box, which could present a safety hazard, modules should be oriented with the junction box in the uppermost position. The junction box should not be mounted in a depression when mounted on a flat surface.



**WARNING:** Use gloves when handling modules.



**WARNING:** Do not place anything on the modules, even for a moment.



**WARNING:** The installation area of the panel should be cleaned before installation, and everything that could cause flame or fire should be removed.



**QUICK TIP:** To generate the most electricity, the module should face directly south if it is in the Northern Hemisphere and face directly north if it is in the Southern Hemisphere.

## MAXIMUM BENDING

TESUP flexible modules are flexible but not rollable or foldable. They can be bent up to a maximum curvature of 30 degrees for permanent mounting on curved surfaces.

Excessive or frequent bending should be avoided as it can lead to damage and hazardous situations. Bending should be evenly distributed across the module, as concentrated bending can harm solar cells. When handling, hold the module vertically by the edge without applying excessive pressure to the cell edges. Avoid holding by the short ends or corners to prevent excessive bending under their own weight.

## MECHANICAL INSTALLATION

When installing the modules, follow general safety guidelines, electrical installation regulations, construction codes, and local/national rules. If mounting by screwing or riveting, use only the existing holes on the backplate to avoid voiding your warranty.

Ensure the support structure that the panel will be installed on can withstand all weather conditions, including wind, snow, salt (for marine applications), and storms. Avoid excessive bending or flexing of the support structure, which may harm panel components, reduce efficiency, and cause internal structural damage.



**WARNING:** High temperature reduces the efficiency of solar cells. The mounting of the panel must permit air to freely circulate on the backside of the panel. This reduces the temperature and results in better performance.



**IMPORTANT:** After installation re-adjust and tighten the screws and bolts.

## ELECTRICAL INSTALLATION

A photovoltaic module behaves like a current generator (such as a battery) and therefore has a positive and a negative contact.

When connecting multiple modules, ensure that the total voltage/current of the PV array remains below the maximum specifications of the inverter, solar charge controller, or other connected devices, cables, and connectors. Please also note to:

- Use cables with a sufficient cross-section to prevent significant voltage drop. Always choose cables designed for photovoltaic installations and resistant to atmospheric conditions.
- Avoid connecting modules with different orientations or angles of inclination within the same string.

Ensure that the cables are not under stress. We recommend using cable ducts for added UV protection and to prevent cable sagging.



**WARNING:** To prevent electric shock, fire, and injury, do not touch terminals while a panel is exposed. Use suitable guards, such as insulated tools and gloves, to avoid direct contact with the solar panel output terminals.

Multiple TESUP Flexible Solar Panels can be connected to batteries in various ways, including individual connections, series connections to increase voltage, or parallel connections to increase current:

- For a series connection, link the positive terminal of one module to the negative terminal of the next module.
- For a parallel connection, connect the positive terminals of one module to the positive terminals of others and likewise for the negative terminals.

A series connection is shown in the diagram:

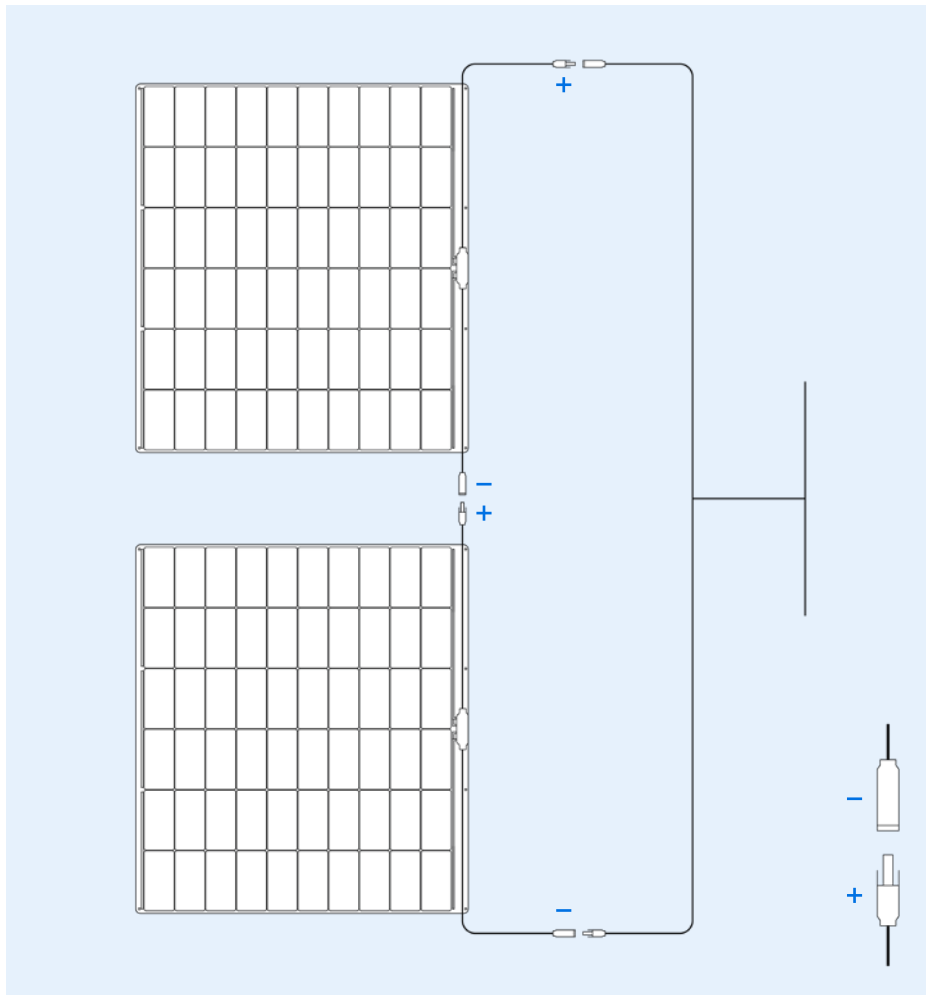

A parallel connection is shown in the diagram:

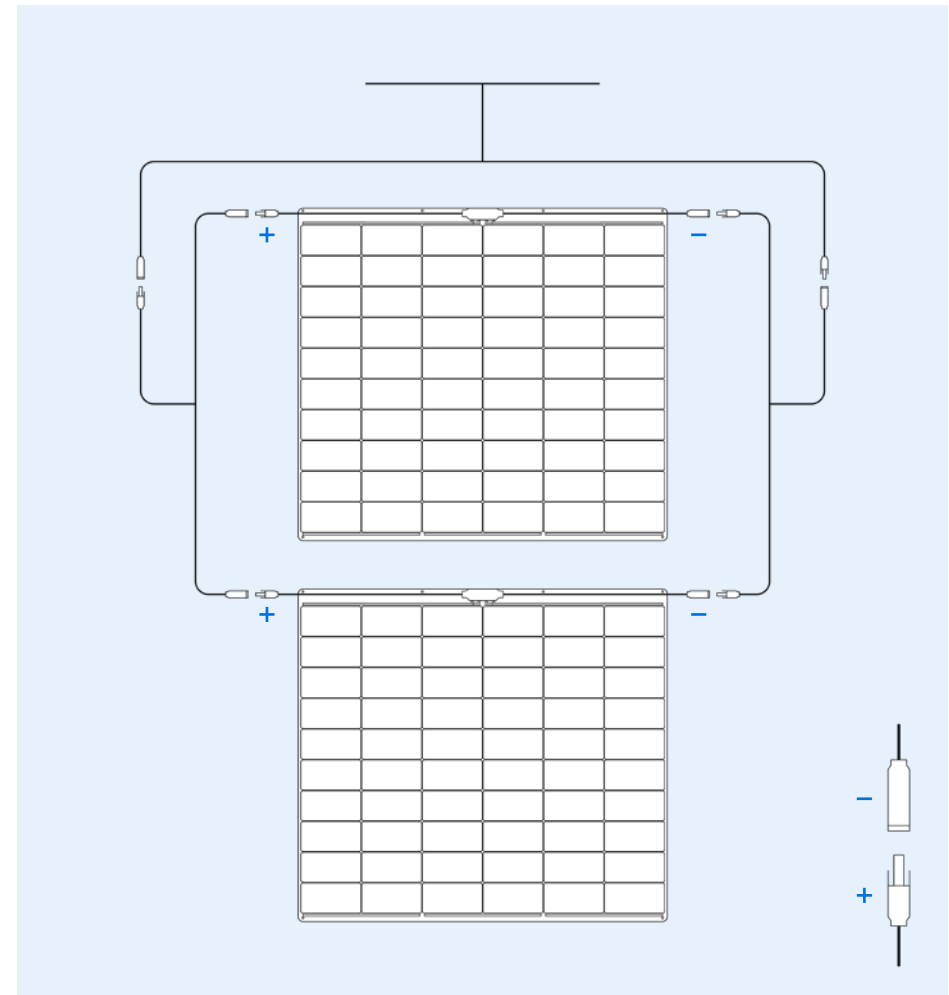

**WARNING:** It is not recommended to connect solar panels in marine applications in series.



**WARNING:** The modules have MC4-type connectors. You should never open the MC4 connectors while the wires are active. Connectors are only designed to be opened without any load.

## Maintenance & Cleaning

Solar panels require minimal maintenance due to their lack of mechanical parts. Maintenance can be simplified to these procedures:

- Keep the panel clean, especially in a marine environment; wash it regularly with fresh water to prevent salt build-up and reduce the risk of damage.
- Periodically inspect the panel for signs of delamination or issues with mounting and securing.
- Regularly check electrical connections and wires.
- Periodically assess the system for electrical efficiency and signs of deteriorating output.

Interval	Activity
Daily	Inspect for damage on the cables.
	Inspect for damage on the solar modules.
	Inspect for damage on the junction box.
	Check electrical connections.
Yearly	The efficiency of the product should be checked by a technician.

## POSSIBLE BREAKDOWNS

TESUP solar panels undergo rigorous quality controls before sale, making manufacturing-related failures rare. Possible causes of non-manufacturing-related failures include:

- Cells breaking due to excessive bending or mechanical stress,
- Cells breaking due to mechanical stress or physical abuse of the panel,
- Cells breaking due to improper installation on a solid surface, such as air bubbles causing damage,
- Water infiltration and entrapment between the panel and a solid surface,
- Water ingress into the junction box.



**WARNING:** If the foil on the product is torn, the product becomes unusable and poses a risk of electric shock.



**WARNING:** There is no guarantee for overheating damage caused by improper installation.

## Removal From Service & Disposal

It is important to note that the system must be dismantled and disposed of properly by a qualified professional.

Caution should be taken due to potential stored energy and the possibility of breakage.



**WARNING:** Risk of injury and potential breakage may occur if the solar panel system is dismantled by unqualified individuals without suitable training. It is crucial to dismantle the system correctly by a qualified person to ensure safety and prevent damage.

Dispose of the individual components in accordance with the guidance of the responsible local authorities, as needed.

Solar Panel System	
Wiring, electrical components	Dispose of as electronic scrap
Mechanical components	Segregate prior to disposal



**WARNING:** Stored energy



**QUICK TIP:** Take note of the relevant parameters at the site and keep them readily available when contacting the manufacturer or specialist dealer.



## Declaration Of Conformity

TESUP

### Declaration of Conformity



**Manufacturer:** TESUP GLOBAL AS  
22 Sutton Lane, North Chiswick, London W4 4LD, United Kingdom

#### PRODUCTS

**Product Type:** Flexible Solar Panel

**Model Name:** TESUP 230W Flexible Solar Panel

**This declaration of conformity is issued under the sole responsibility of the manufacturer TESUP GLOBAL AS.**

The equipment of the declaration is described above is in conformity with the relevant Union harmonization legislation:

1. 2014/35/EU OF THE EUROPEAN PARLIAMENT AND OF THE COUNCIL of 26 February 2014 on the harmonization of the laws of the Member States relating to the making available on the market of electrical equipment designed for use within certain voltage limits (recast).
2. Directive 2011/65/EU of the European Parliament and of the Council of 8 June 2011 on the restriction of the use of certain hazardous substances in electrical and electronic equipment (recast) Text with EEA relevance.

Used harmonized standards and other standards:

1. EN IEC 61215-1:2021
2. EN IEC 61215-2:2021
3. EN IEC 61730-2:2018

TESUP

### Declaration of Conformity



**Manufacturer:** TESUP GLOBAL AS  
22 Sutton Lane, North Chiswick, London W4 4LD, United Kingdom

#### PRODUCTS

**Product Type:** Flexible Solar Panel

**Model Name:** TESUP 230W Flexible Solar Panel

These products as described above are in conformity with the relevant UK designated legislation and statutory instruments (and their amendments):

1. S.I. 2016:1101 Electrical Equipment (Safety) Regulations 2016
2. S.I. 2012:3032 The Restriction of the Use of Certain Hazardous Substances in Electrical and Electronic Equipment Regulations 2012

References to the relevant designated standards used or references to the technical specifications in relation to which conformity is declared:

1. BS EN IEC 61215-1-1:2021
2. BS EN IEC 61215-1-2:2021
3. BS EN IEC 61730-2:2018



Product Manuals

# TESUP Wizard Sensor Terminal

(Edition Wind & Solar)

# TESUP Wizard Sensor Terminal

(Edition Wind & Solar)

The TESUP Wizard is a compact sensor terminal device for monitoring wind and solar data directly on your mobile phone. This compact tool collects anemometer and pyranometer data, delivering it to your My TESUP App in seconds.

It offers accurate data measurement tailored to your location, facilitating informed decisions regarding clean energy investments. It is compatible with TESUP anemometer and pyranometer (sold separately) for precise data monitoring, and requires no assembly, being ready for immediate use. Users can quickly pair it with the MyTESUP app via QR code for seamless data monitoring. Additionally, the package includes a 1.2m Jack-to-USB cable for flexible installation, compatible with any USB-to-Plug adaptor (adaptor not included).



**IMPORTANT:** The TESUP Wizard is a standalone device designed for use even without any energy system. However, its advanced data features are already built into the TESUP V7 Wind Turbine. No additional purchase is necessary if you already own or plan to acquire the TESUP V7.

## Important Safety Instructions

- **All TESUP products are for outdoor use only.**
- Pay attention to any damage to the components on the product and the cable surface and ends.
- Please follow the grounding techniques as specified in the NEC (National Electric Code).

- When plugging in the product, it is recommended to choose a day with calm weather conditions as well as making sure that the product and its surroundings are dry.
- Keep the product out of reach of children and animals as much as possible.

## MODIFICATIONS BY THE USER

To ensure compliance with the Electromagnetic Compatibility Directive (EMC) (2014/30/EU), it is essential that only original TESUP product components are used and the system is properly erected. The use of components from other manufacturers or any modifications or changes made by the user is strictly prohibited. Such actions could invalidate the declaration of conformity.



**WARNING:** Avoid using cables and components from other devices. Using any third party equipment may affect the performance of the product and will result in a void warranty.

## RESIDUAL RISKS

The user manuals in this book includes relevant sections that describe any residual risks that may arise during operation or maintenance.

## General Instructions

Before you begin installing your system, read the entire user manual section of this book. Following the instructions and recommendations in this manual section will help assure safe and enjoyable use of your new product. Please take the time to read through this manual prior to operation.

- TESUP reserves the right to modify its products, technical specifications, and these installation instructions without prior notice.
- These guidelines are specific to TESUP Wizard. Please read and follow the instructions carefully, including all safety recommendations.
- Never open the case and expose the internal components. Opening the product and modifications will void your warranty.
- The installation techniques, handling, and use of this product are beyond company control. Therefore, TESUP assumes no responsibility for loss, damage or expense resulting from improper installation, handling, or use.
- The module contains no user-serviceable parts; do not attempt repairs.
- Avoid standing on, dropping, scratching, or allowing objects to fall on the modules to prevent potential damage and warranty avoidance.
- Avoid placing objects on the product to prevent potential damage or staining of the surface.
- Do not install or handle the product when they are wet. Do not allow water to pool on or near the product.
- Do not cut or pierce the module, this might cause live components to be exposed and/or damage the product.
- Do not bend or apply excessive force to the cables.
- Do not use this product near flammable or explosive substances.
- Please do not apply any protections, paint or varnish to the product.
- Do not drop heavy or sharp items onto the product.
- Do not dismantle or remove any part or label affixed by the manufacturer.



**WARNING:** This product is not waterproof. Avoid installing the product in locations where it may be submerged in water for lengthy periods. Installation, maintenance and removal of the product must take place on dry surfaces.



**WARNING:** The installation area of the product should be cleaned before installation, and everything that could cause flame or fire should be removed.

### PRODUCT FEEDBACK

Please notify the manufacturer or their authorised representative about any of the following:

- Accidents
- Potential safety hazards associated with the system
- Uncertainties arising from the translation of the original instructions
- Description of the TESUP Wizard system

### OPERATING & INSTALLING CONDITIONS

Please make sure that:

- The system has been erected correctly.
- All operating personnel have read and fully understood the translation of the original instructions.
- The system is properly maintained and repaired.

## INTENDED USE

- Install or use the TESUP Wizard system for its intended use only.
- Observance of the original instructions and compliance with the maintenance and repair instructions are essential preconditions of use for the intended purpose.

## REASONABLY FORESEEABLE MISUSE

Follow the recommended guidelines for optimal performance and safety. Deviating from these guidelines may release the manufacturer from liability for any resulting damages.

- For your best protection and peace of mind, please note that the manufacturer cannot be held responsible for damages resulting from equipment alterations or improper handling during assembly, installation, start-up, operation, maintenance, or repair.
- For peak performance and reliability, use only manufacturer-supplied original parts and accessories. Non-approved parts may lack proper testing and could lead to reliability issues. The manufacturer is not liable for damages resulting from non-approved parts or accessories.
- Reasonably foreseeable misuse includes:
  - Operating the system outside the manufacturer's specified parameters.
  - Making modifications or changes to the system without obtaining written approval from the manufacturer.
  - Using non-original parts that are not recommended by the manufacturer.
  - Operating the system in water.

By adhering to the manufacturer's guidelines, you can safeguard your product and enjoy its benefits for years to come.

## Storage & Operation

### STORAGE

**Ambient temperature:**

-15 to +40°C.

**Storage location:**

Dry, frost-free

### OPERATION

**Ambient temperature:**

-15 to +40°C.

The Company (TESUP) is not responsible for modifications and external damages. While we take utmost care to ensure that product descriptions, pictures, information, and prices are correct, we do not accept any liability for any inaccuracies, errors or omissions. We do not accept any liability for any inaccuracies for incorrect usage of TESUP products. We do not take any responsibility for installation and modifications mistakes for the products which are delivered disassembled. Colors may differ slightly from those shown on the website due to limitations of internet, software, and computer hardware technologies. In line with our policy of continuous product improvement, TESUP reserves the right to change, vary or make different the product specification without prior notification.

## Technical Details

### PARAMETER & DIMENSIONAL DETAILS

SPECIFICATIONS	
Type	Sensor terminal (Edition Wind & Solar)
Operating Temperature Range	-15 to +40 °C
Material	Aluminium
Weight	250 gr (0.55 lbs)
Dimensions	135 x 112 x 60 mm (0.44 x 0.37 x 0.2 ft)

### SYSTEM COMPONENTS



### TESUP WIZARD SENSOR TERMINAL COMPONENTS



## GENERAL ARRANGEMENT AND DIMENSIONS

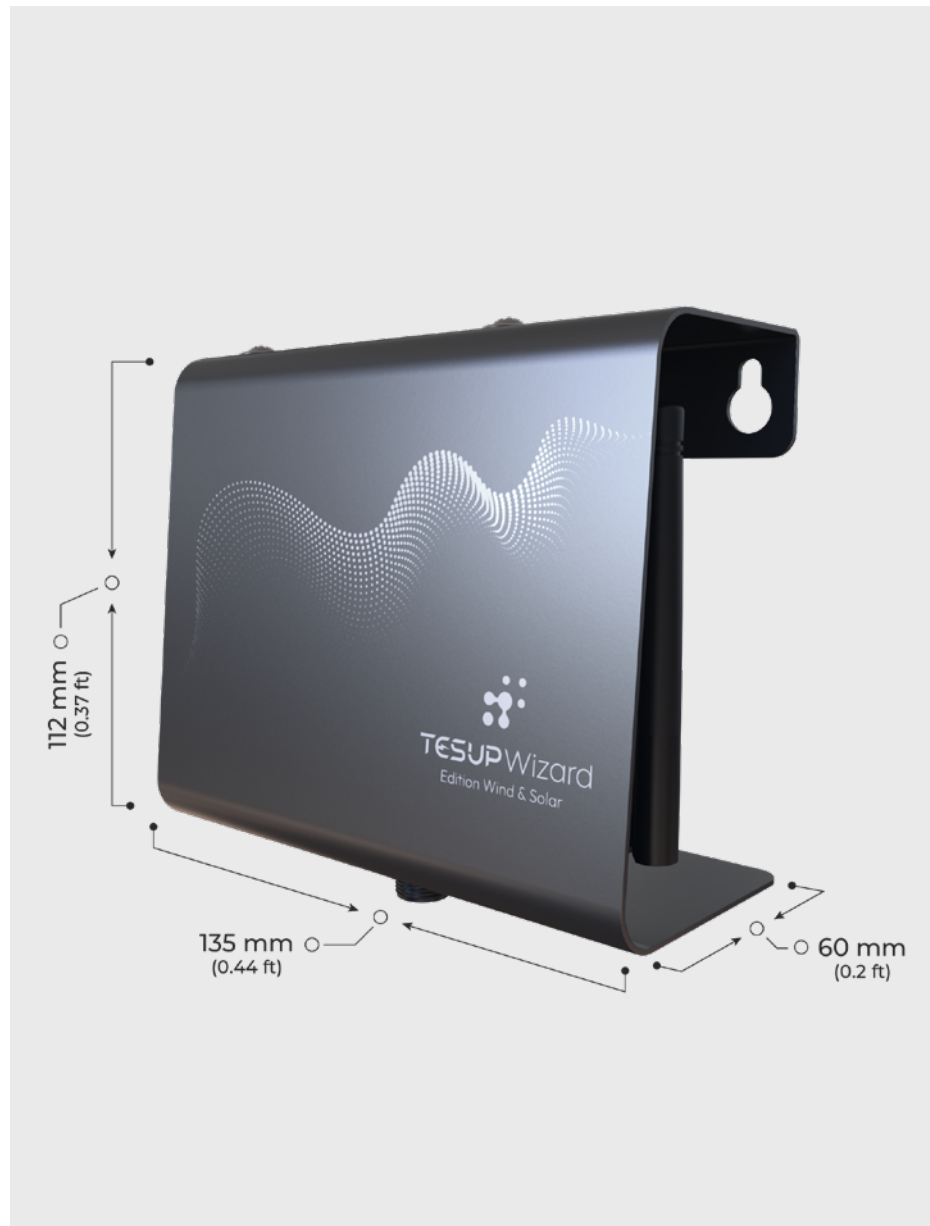

## USAGE SCENARIOS

There are three options available for incorporating add-ons. TESUP Wizard can function with solely a pyranometer to provide solar data, solely an anemometer for wind data, or both to offer a comprehensive dataset for analysis.



**QUICK TIP:** You can easily fix the product to the wall with the hanging holes on the back of the product.

## Maintenance & Cleaning

The TESUP Wizard requires minimal maintenance due to its lack of mechanical parts. Maintenance can be simplified to these procedures:

- Keep the product clean.
- Regularly check electrical connections and wires.
- Periodically assess the system for efficiency and signs of deteriorating output.

Interval	Activity
Daily	Inspect for damage on the cables.
	Inspect for damage on the product.
	Check electrical connections.



**WARNING:** There is no guarantee for overheating damage caused by improper installation.



**WARNING:** Although TESUP Wizard does not require extensive maintenance work, the sensors must be away from dust in order to make accurate measurements.

## Removal From Service & Disposal

It is important to note that the system must be dismantled and disposed of properly by a qualified professional.

Caution should be taken due to potential stored energy and the possibility of breakage.

### DISPOSAL OF THE TESUP WIZARD SYSTEM AND COMPONENTS

Dispose of the individual components in accordance with the guidance of the responsible local authorities, as needed.

TESUP Wizard System	
Wiring, electrical components	Dispose of as electronic scrap
Mechanical components	Segregate prior to disposal



**QUICK TIP:** Take note of the relevant parameters at the site and keep them readily available when contacting the manufacturer or specialist dealer.



Product Manuals

# Old Products



# TESUP V7

Vertical Axis Wind Turbine

# TESUP V7

## SYSTEM COMPONENTS

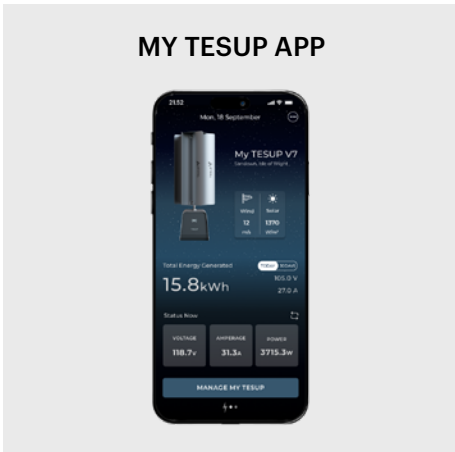

**IMPORTANT:** Please note that the inverter needed for on-grid systems must be supplied separately.

## DIFFERENT V7 BLADE SETS

### INCLUDED IN THE BOX

#### High Wind Blade Set

Optimum Performance Between 7 - 35 m/s



### INCLUDED IN THE BOX

#### Moderate Wind Blade Set

Optimum Performance Between 4 - 25 m/s



### OPTIONAL

#### Low Wind Blade Set

Optimum Performance Between 3 - 20 m/s



WIND TURBINE COMPONENTS

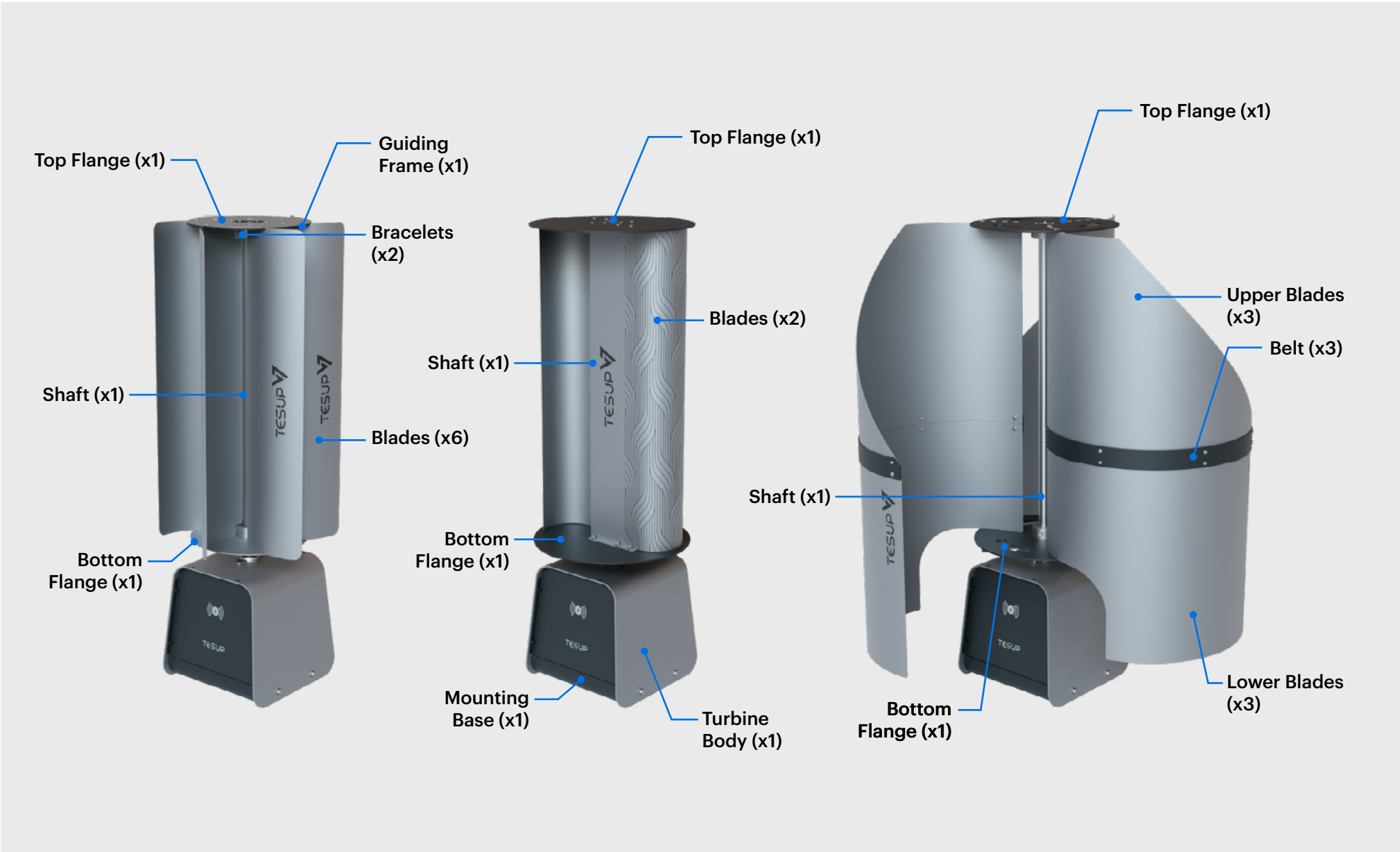

**PARAMETER & DIMENSIONAL DETAILS**

<b>GENERATOR</b>	
Type	9kW vertical axis wind permanent magnet generator
Weight	24.5 kg (54 lbs)
Max. Power	9kW
Operating Circuit Voltage	0-220V
Current	3-Phase
Start Of Charging	4 m/s
Base Plate Material	Sheetmetal
Direction Of Rotation	Clockwise
Test Standards	EN 61000-6-1 (electromagnetic compatibility – immunity) EN 61000-6-3 (electromagnetic compatibility – emissions)

<b>ROTOR BLADES - V7 HIGH WIND</b>	
Material	Aluminium
Diameter	460 mm (1.50 Feet)
Weight Per Rotor Blades	100 g (0.22 lbs)
Direction Of Rotation	Clockwise
Starting Wind Speed	5 m/s (4 m/s afterwards)
No. Of Blades	6
Max Rpm	931
Max Wind Speed	35 m/s
Noise	40 dB

<b>ROTOR BLADES - V7 MODERATE WIND</b>	
Material	Aluminium
Diameter	400 mm (1.31 Feet)
Weight Per Rotor Blades	850 g (1.87 lbs)
Direction Of Rotation	Clockwise
Starting Wind Speed	4 m/s (3 m/s afterwards)
No. Of Blades	2
Max Rpm	800
Max Wind Speed	25 m/s
Noise	35 dB

<b>ROTOR BLADES - V7 LOW WIND</b>	
Material	Aluminium
Diameter	1200 mm (3.93 Feet)
Weight Per Rotor Blades	750 g (1.65 lbs)
Direction Of Rotation	Clockwise
Starting Wind Speed	3 m/s
No. Of Blades	3
Max Rpm	700
Max Wind Speed	20 m/s
Noise	35 dB

POWER CURVE

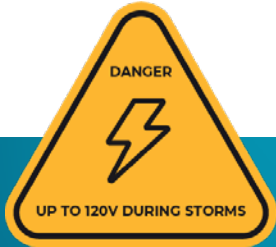

TESUP

TESUP 9 KW GENERATOR - ELECTRICAL POWER CURVE

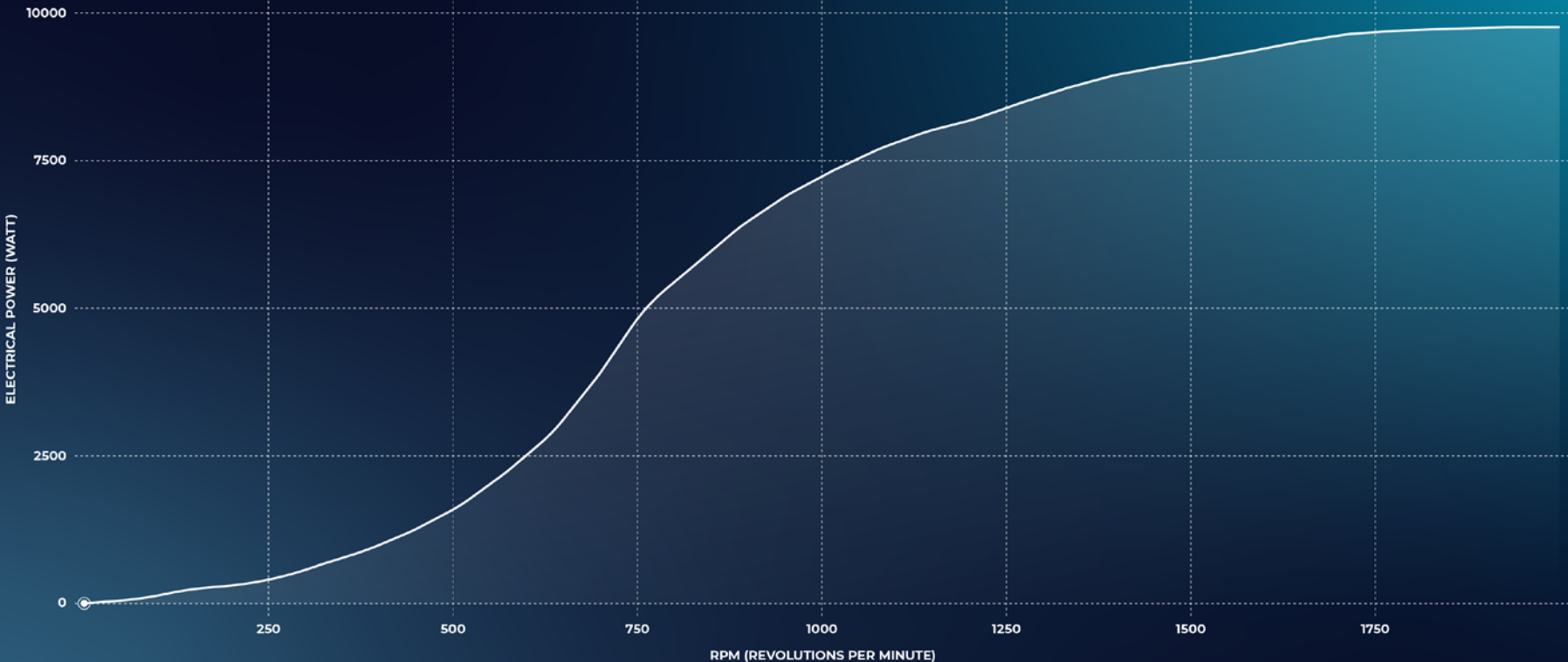

Graph values represent ideal conditions in the initial month but may decrease over time (4% annually under Standard Test Conditions). Variation depends on location and external factors.



**IMPORTANT:** Humidity, turbulence and the ion levels in the air can impact your turbine's performance.

GENERAL ARRANGEMENT AND DIMENSIONS

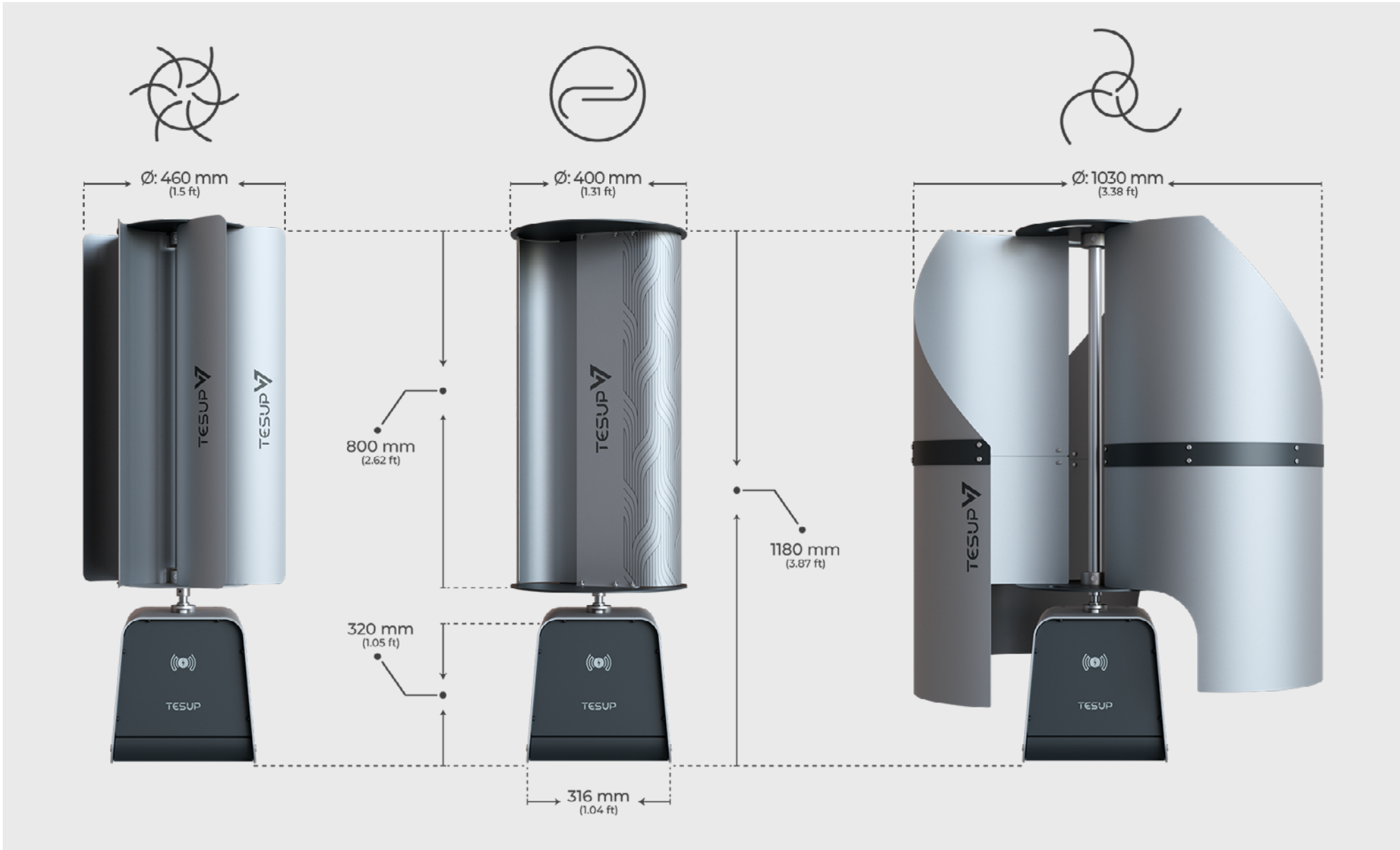

## Assembling the Wind Turbine

### MOUNTING DETAILS

The mounting surface must have a sufficient load-bearing capacity. The size and structure of the foundation depend on the ground/surface characteristics.

[Click here](#) to watch the TESUP V7 turbine assembly video.

Fastening packs available in your package and you will be using for the mounting base assembly:



1. Carefully open the packaging, taking care not to damage any of the components. After verifying the shipment for completeness, carefully remove all components from the box.
2. Fix the mounting base to the turbine's final location.



**QUICK TIP:** It is recommended to consult with a qualified structural engineer for advice on determining the optimal mounting surface.



**WARNING:** The mounting base of the wind turbine must be fixed to the mounting surface and checked that it is fully stable, before moving on to the next steps with wind turbine installation.



3. Fix the turbine body to the turbine's mounting base.



4. Insert the shaft on the rotor shaft (The double holes of the shaft should be on the downside, and the single hole should be on the upside.).



**WARNING:** Before proceeding with the blade set installation, ensure that the mounting base is securely fixed to the mounting surface and thoroughly checked for stability.

[High wind speed blades assembly >>>](#)

[Moderate wind speed blades assembly >>>](#)

[Low wind speed blades assembly >>>](#)

## ASSEMBLING THE HIGH WIND SPEED BLADES

[Click here](#) to watch the TESUP V7 turbine assembly video.

Fastening packs available in your package and you will be using for this blade set's assembly:



1. Carefully open the packaging, taking care not to damage any of the components. After verifying the shipment for completeness, carefully remove all components from the box.
2. Fix the turbine body to the turbine's final location. Ensure that the mounting base is securely fixed to the mounting surface and thoroughly checked for stability. [Click here](#) to see the mounting details.

3. Mount the bottom bracelet to the bottom flange, taking into account the location of the holes and the direction in which the blades will be installed.

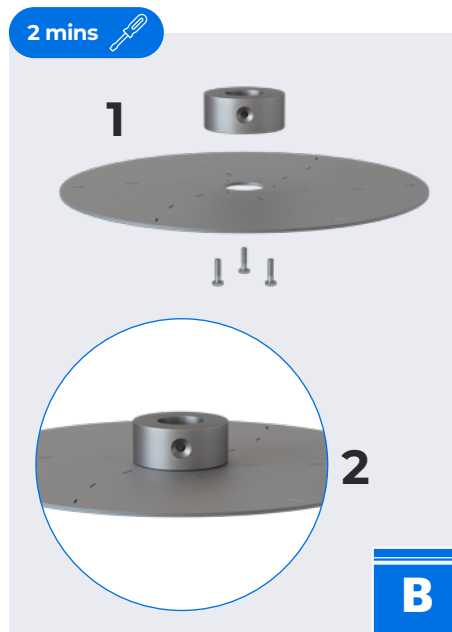

4. Mount the top bracelet to the guiding frame, taking into account the location of the holes and the direction in which the blades will be installed.

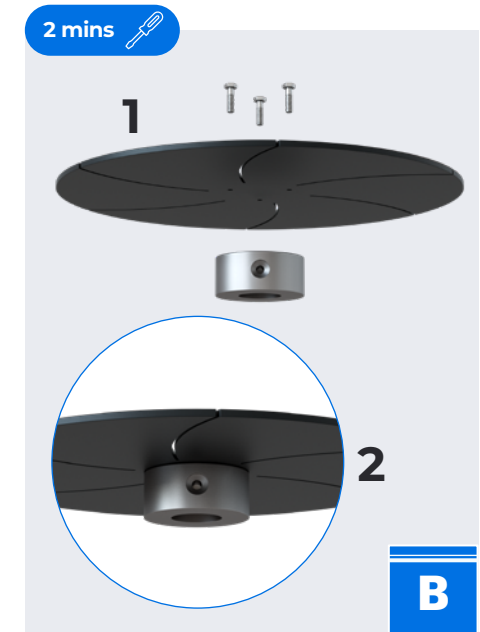

5. Mount the bottom flange to the shaft.

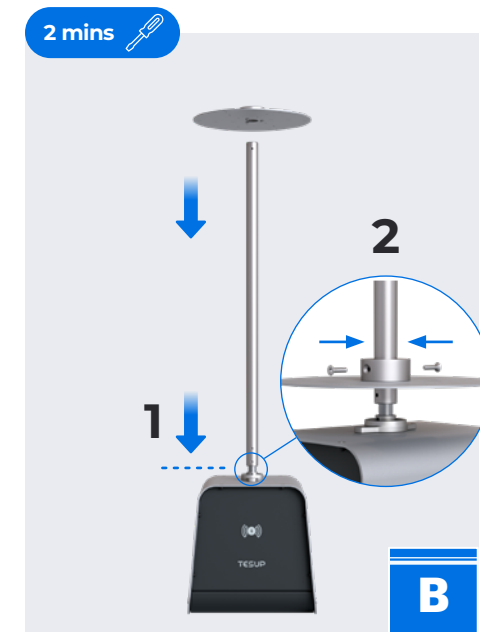

6. Mount the guiding frame to the shaft.



8. Insert the snaps on the blade through the housings on the bottom flange.

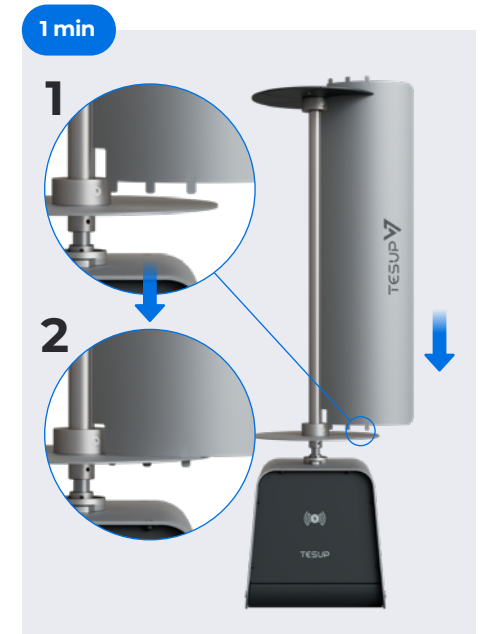

7. Insert the turbine blades into the designated housings on the bottom flange through the guiding frame.



9. Repeat steps 7 and 8 for the remaining blades.



**10.** Insert the top flange and ensure that all the snaps pass through the housings on the top flange.



**12.** Turn the upper body upside down. Holding it from both the top and bottom flanges, carefully place the upper body on a flat surface with the top flange facing the floor.



**11.** Carefully bend all the top snaps on the blades using a mallet.

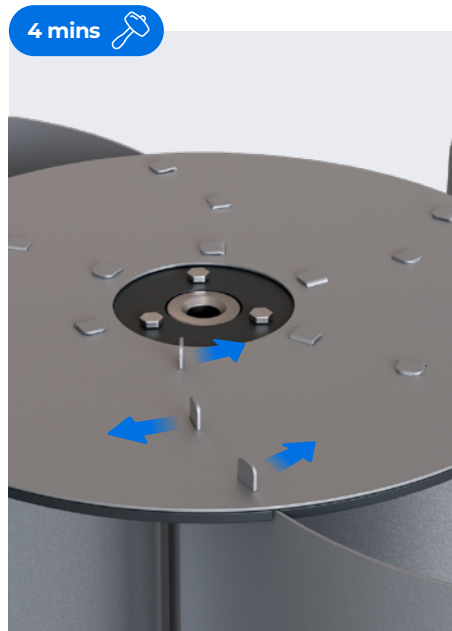

**13.** Carefully bend all the bottom snaps on the blades using a mallet.

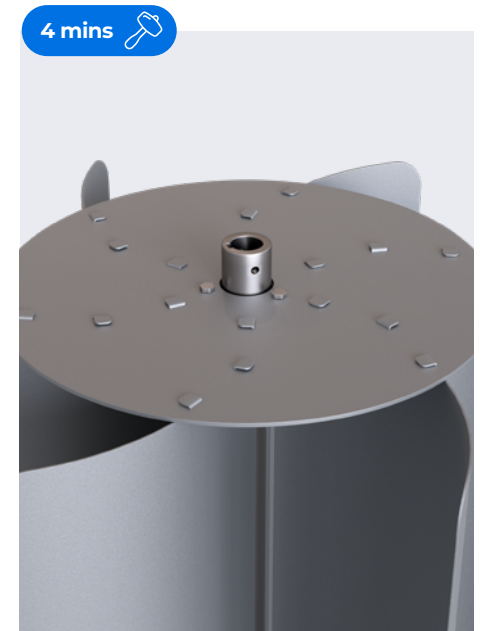

**14.** Flip the upper body, making sure the top flange is facing up again. Insert the shaft on the rotor shaft.



**15.** Fix the upper body to the base, using the grub screws provided.

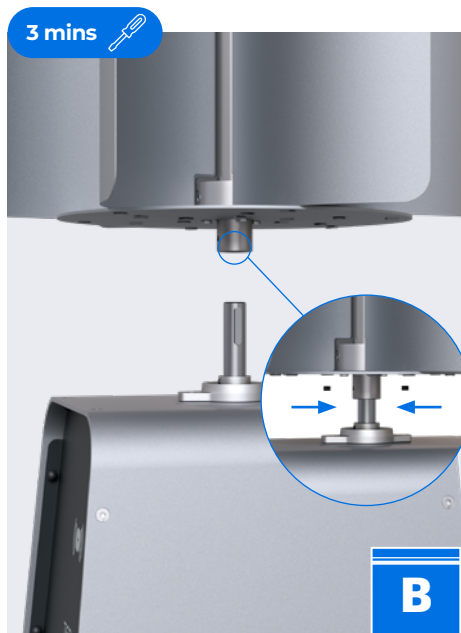

**16.** If there is a battery in the system (in the case of off-grid connections), the maximum voltage value must be manually adjusted either through the “Manage My TESUP” section in the My TESUP App or using the rotary encoder on the body.



**IMPORTANT:** If a short circuit occurs, the turbine will activate its braking system, preventing the blades from turning.



**WARNING:** Incorrect or loose fastening can adversely affect the efficiency of your turbine, potentially causing damage and posing a risk of injury. Ensure that all fasteners are properly tightened.

## ASSEMBLING THE MODERATE WIND SPEED BLADES

[Click here](#) to watch the TESUP V7 turbine assembly video.

Fastening packs available in your package and you will be using for this blade set's assembly:



1. Carefully open the packaging, taking care not to damage any of the components. After verifying the shipment for completeness, carefully remove all components from the box.
2. Fix the turbine body to the turbine's final location. Ensure that the mounting base is securely fixed to the mounting surface and thoroughly checked for stability. [Click here](#) to see the mounting details.

3. Fix the shaft to the base using the grub screws provided.

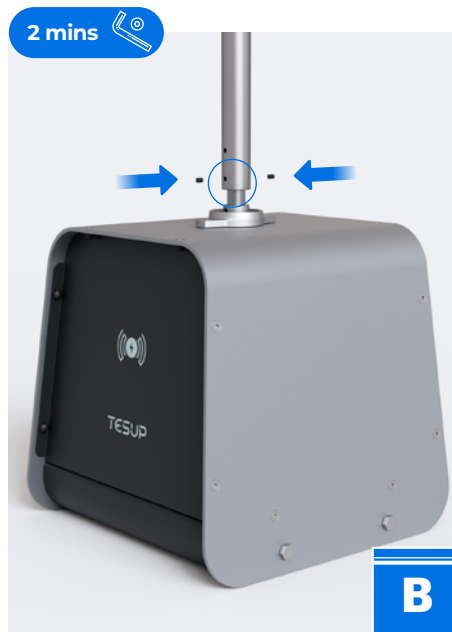

4. Mount the bottom bracelet to the bottom flange, taking into account the location of the holes and the direction in which the blades will be installed.

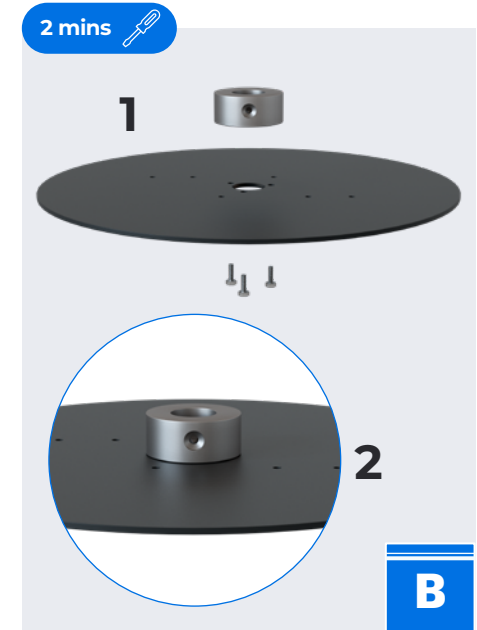

5. Mount the top bracelet to the top flange, taking into account the location of the holes and the direction in which the blades will be installed.

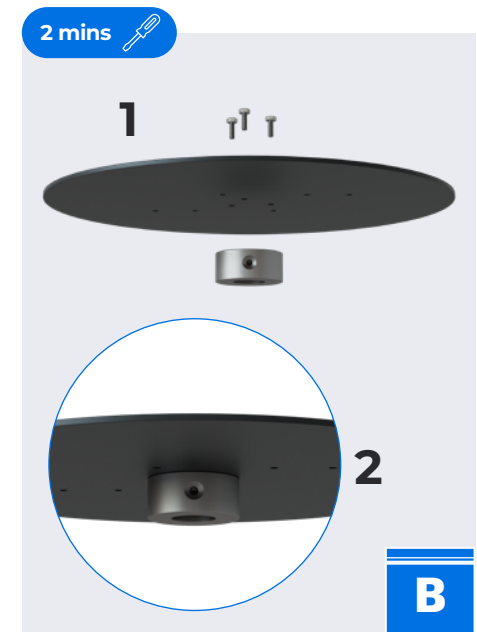

6. Mount the bottom flange to the shaft.

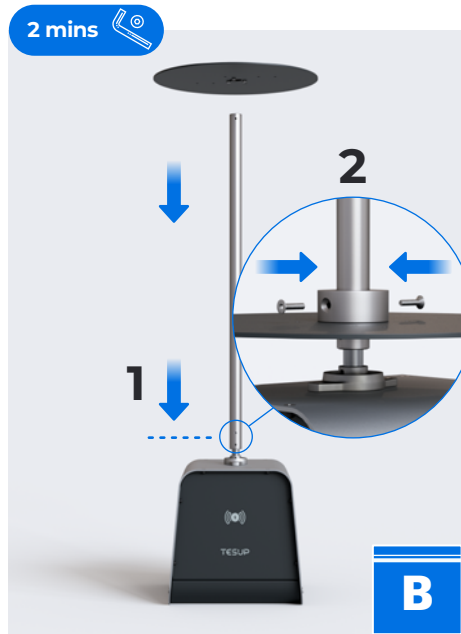

8. Place the blades between the flanges.

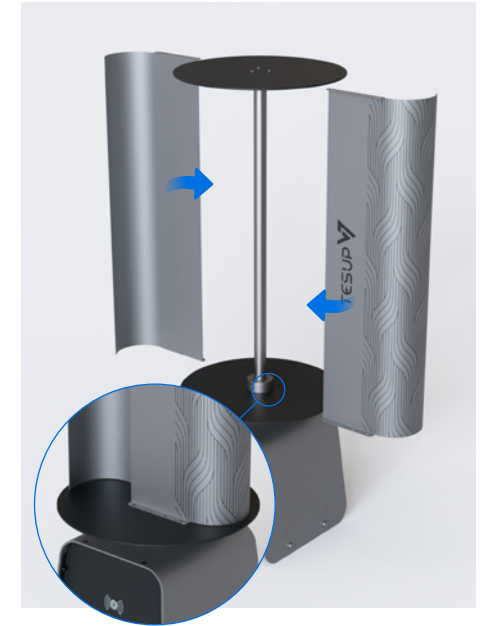

7. Mount the top flange to the shaft.



9. Fix the blades to the bottom flange with the use of fasteners provided.

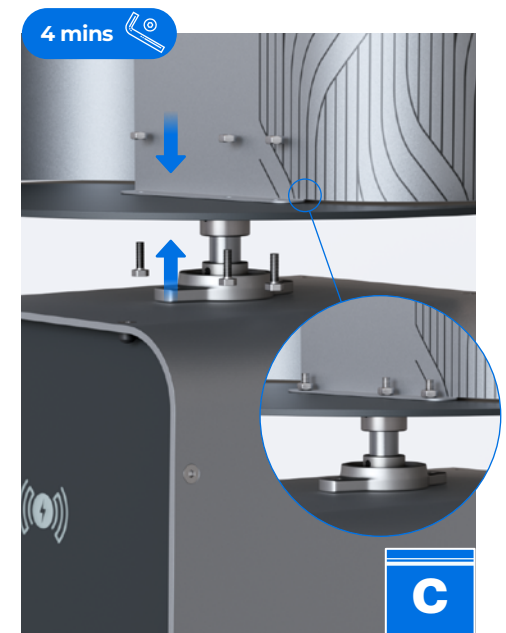

**10.** Fix the blades to the top flange with the use of fasteners provided.

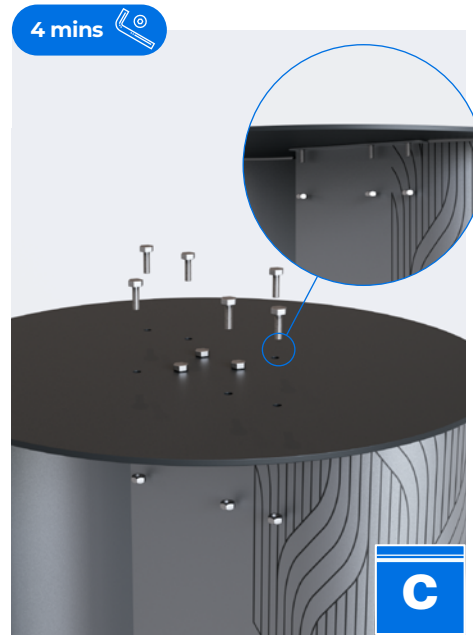

**11.** If there is a battery in the system (in the case of off-grid connections), the maximum voltage value must be manually adjusted either through the “Manage My TESUP” section in the My TESUP App or using the rotary encoder on the body.



**IMPORTANT:** If a short circuit occurs, the turbine will activate its braking system, preventing the blades from turning.



**WARNING:** Incorrect or loose fastening can adversely affect the efficiency of your turbine, potentially causing damage and posing a risk of injury. Ensure that all fasteners are properly tightened.



## ASSEMBLING THE LOW WIND SPEED BLADES

[Click here](#) to watch the TESUP V7 turbine assembly video.

Fastening packs available in your package and you will be using for this blade set's assembly:



1. Carefully open the packaging, taking care not to damage any of the components. After verifying the shipment for completeness, carefully remove all components from the box.
2. Fix the turbine body to the turbine's final location. Ensure that the mounting base is securely fixed to the mounting surface and thoroughly checked for stability. [Click here](#) to see the mounting details.

3. Fix the shaft to the base using the grub screws provided.

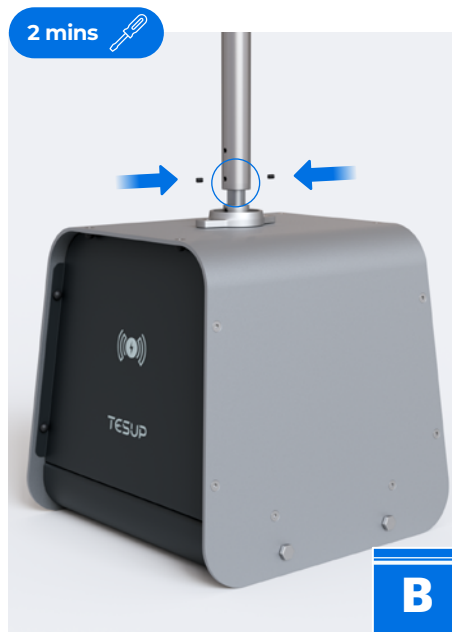

4. Mount the bottom bracelet to the bottom flange, taking into account the location of the holes and the direction in which the blades will be installed.

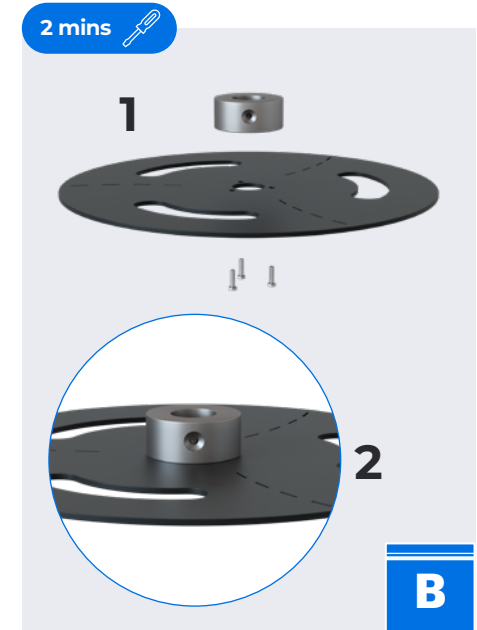

5. Mount the top bracelet to the top flange, taking into account the location of the holes and the direction in which the blades will be installed.



**6.** Mount the bottom flange to the shaft.

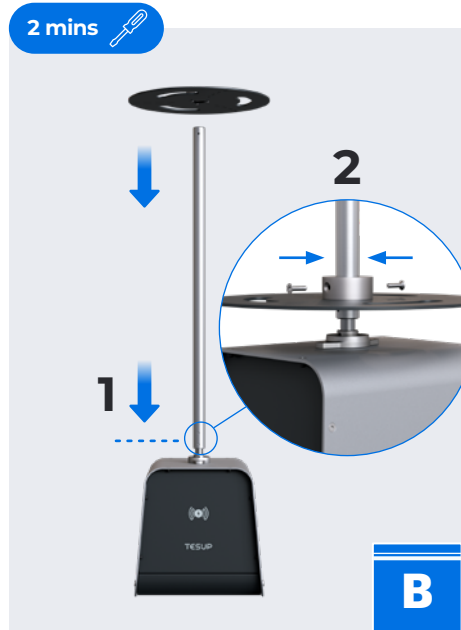

**8.** Mount the upper and lower blades together via the belt. The belt must be fixed to the blades from the outer surface. Repeat these three steps for the remaining blades.

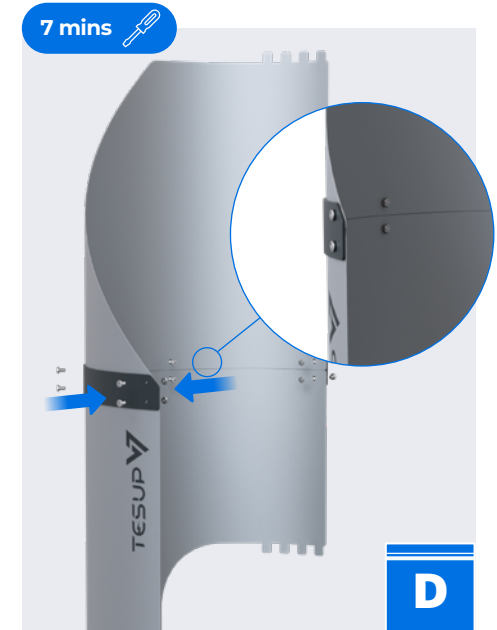

**7.** Bring the upper and lower blades together and take the belt to connect them.

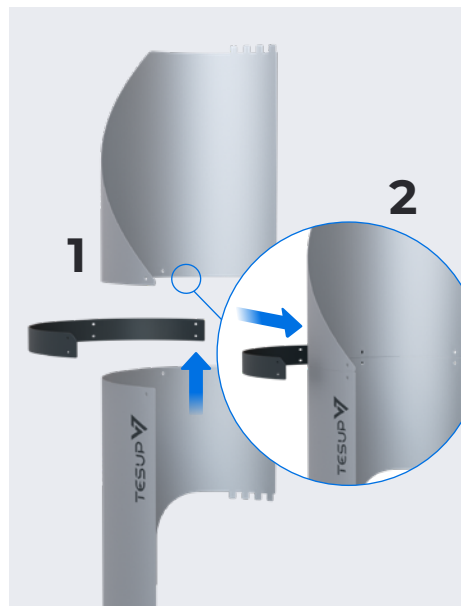

**9.** Insert the blades into the bottom flange by passing the snaps through the designated housings on the bottom flange.



**10.** Insert the top flange, make sure all the snaps on the blades are passing through the housings on the top flange.

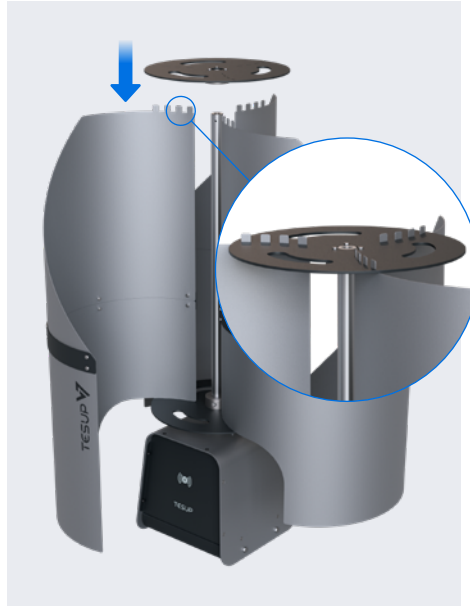

**12.** Carefully bend all the bottom-snaps on the blades using a mallet.



**11.** Mount the top flange to the shaft.

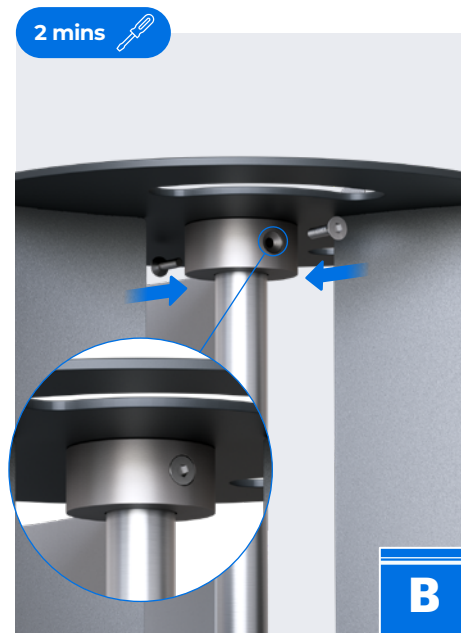

**13.** Carefully bend all the top-snaps on the blades using a mallet.

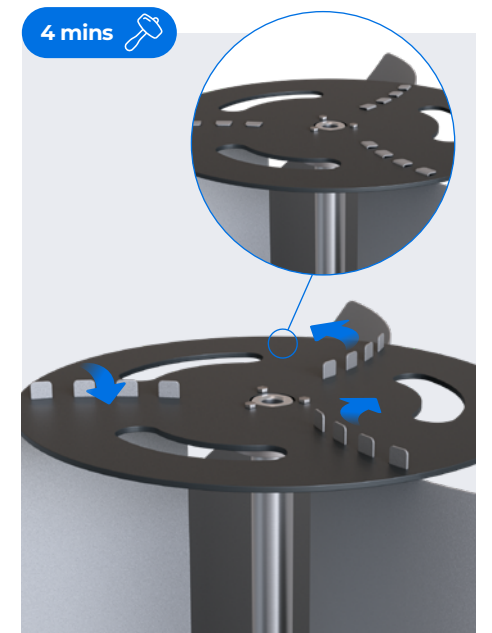



**14.** If there is a battery in the system (in the case of off-grid connections), the maximum voltage value must be manually adjusted either through the “Manage My TESUP” section in the My TESUP App or using the rotary encoder on the body.



**IMPORTANT:** If a short circuit occurs, the turbine will activate its braking system, preventing the blades from turning.



**WARNING:** Incorrect or loose fastening can adversely affect the efficiency of your turbine, potentially causing damage and posing a risk of injury. Ensure that all fasteners are properly tightened.

## WIRING DIAGRAMS

**1. On-Grid Systems:** In this setup, the wind turbine is connected to the grid, allowing for the direct feeding of excess energy into the grid.

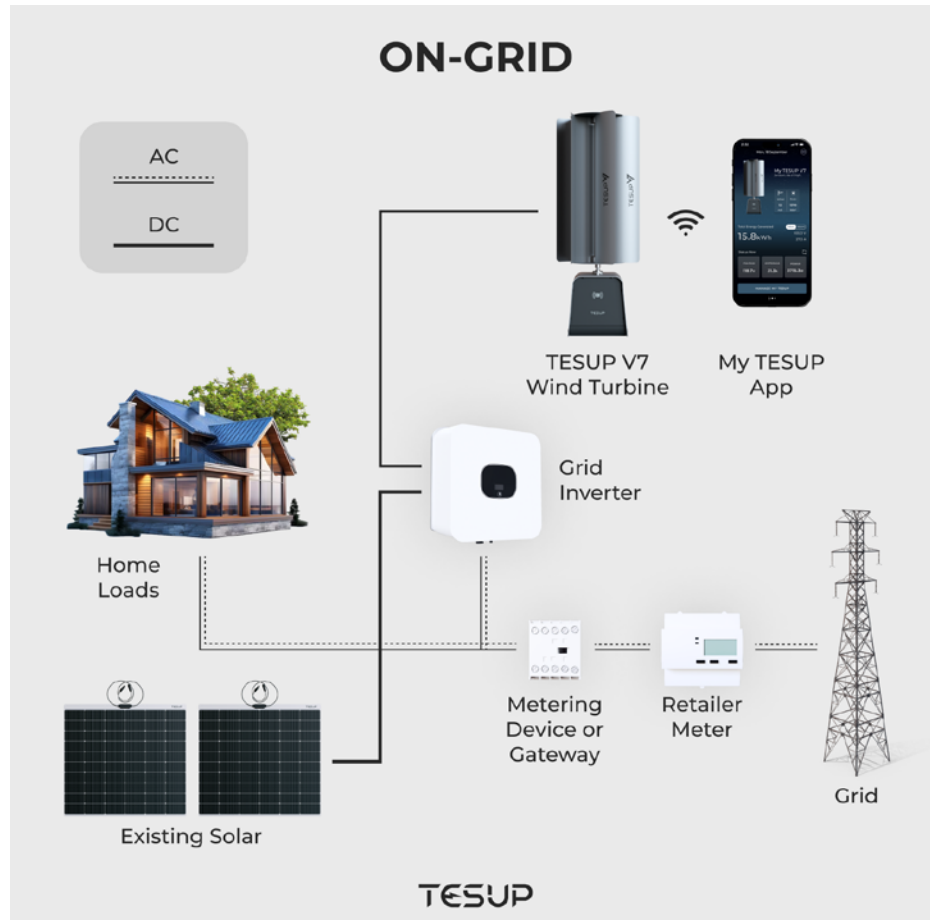

**2. Off-Grid Systems:** This configuration allows for the storage of excess energy generated by the system in batteries for later use.

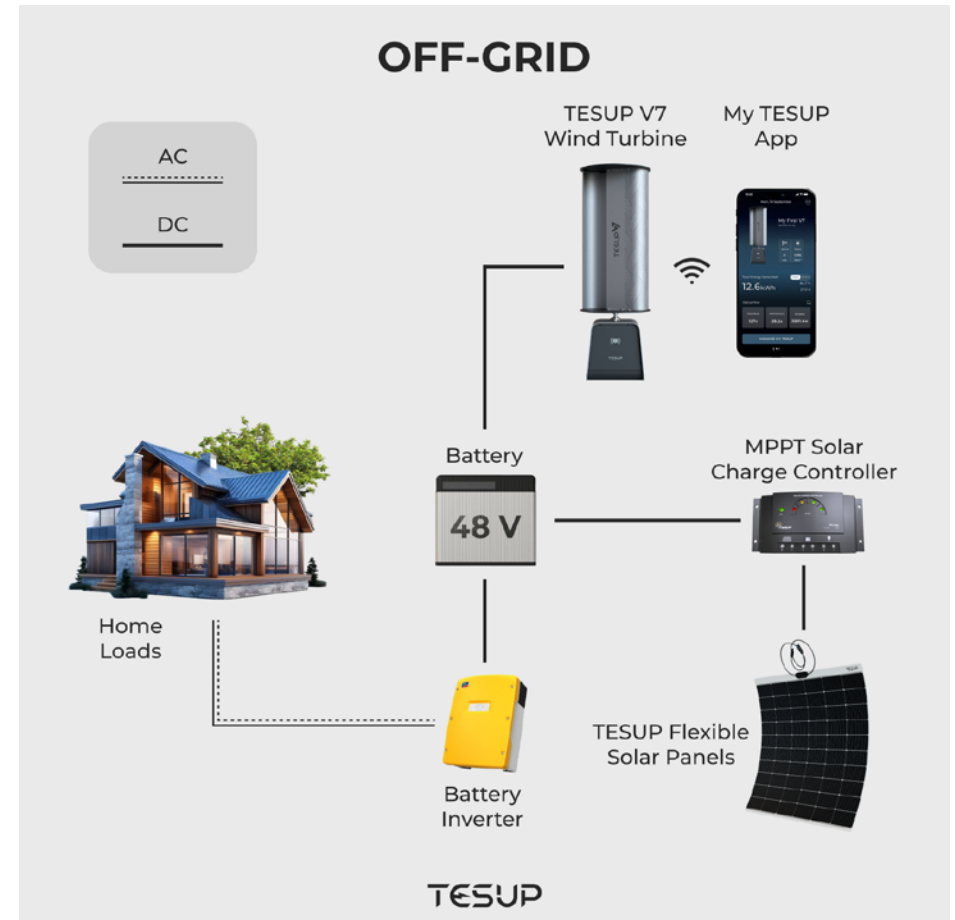

**IMPORTANT:** Please note that the inverter needed for on-grid systems must be supplied separately.



**WARNING:** To operate the system, the TESUP Wind Turbine and an inverter are all required and must be installed outdoors in a dry location.

## My TESUP App

With this app, you can effortlessly monitor the total energy output from all your products over time. By simply scanning the QR code located on your TESUP product, you can remotely control and monitor your TESUP product's operation.



**IMPORTANT:** Your TESUP product must be operational to supply energy to the system during app pairing.



**QUICK TIP:** Your customer account on the TESUP website is not linked to your account in this application. You must first create a separate account.

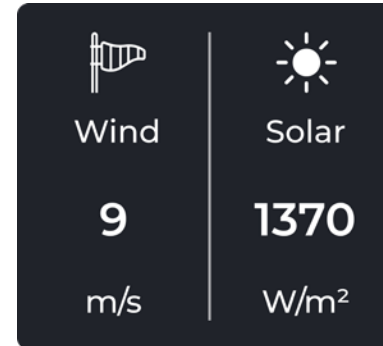

### Track Environmental Data

My TESUP allows you to have real-time access to vital environmental data that directly impacts the efficiency of your TESUP product, such as wind speed and solar irradiance.



**IMPORTANT:** To access wind data, you need an anemometer, which is a wind sensor. TESUP also offers an anemometer as an add-on product upon purchase. You can connect your anemometer to the sensor input on the back of the turbine body.

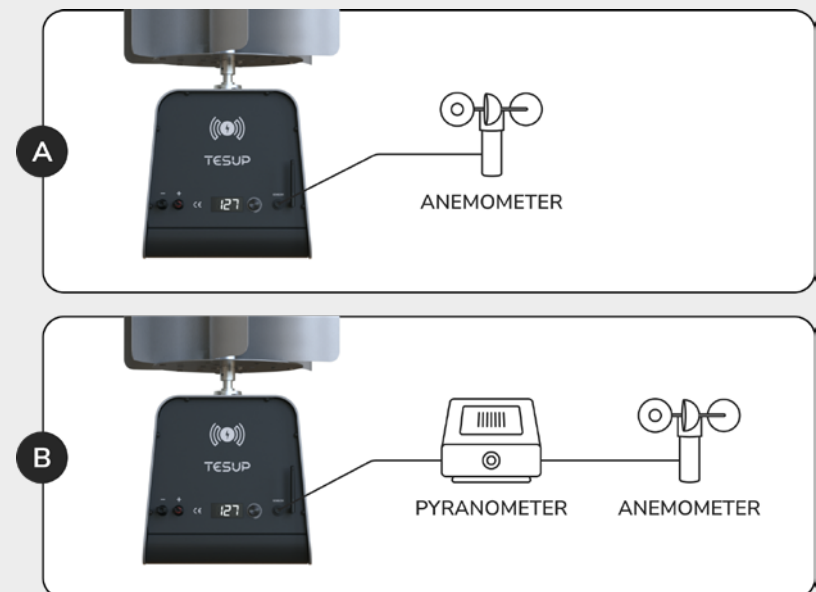

### Real-time Energy Generation Monitoring

My TESUP provides you with up-to-the-minute data on how much energy your assigned products are generating. Whether you're at home, in the office, or on the go, you'll have instant access to the remarkable work being done by your product.

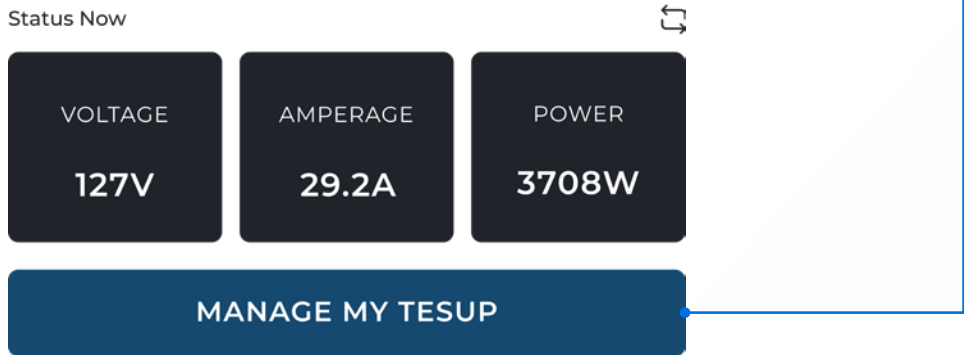

### Adjust Voltage

With this tool you can fine-tune your wind turbine's voltage output to match the specific needs of your energy consumption. By allowing you to make voltage adjustments within a predefined range, this feature ensures that your wind turbine operates at its most efficient, producing just the right amount of energy required.

Your wind turbine operates tirelessly to harness clean energy, but there may be times when you need to halt its operation swiftly and safely. The "Full Brake" function is your tool for precisely that purpose. It offers you the ability to bring your wind turbine to the safest minimum voltage ensuring safety, control, and peace of mind.

### Total Energy Insight, All in One Place

Stay informed about the clean electricity you've generated today, throughout the month, and even access data on average voltage. Use this data to make informed decisions for enhancing your sustainable power generation.

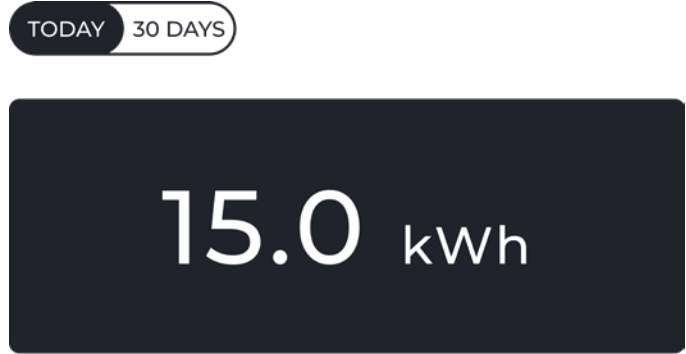



# Hera Wind Pro

Vertical Axis Wind Turbine

# Hera Wind Pro

## WIND TURBINE COMPONENTS

### SYSTEM COMPONENTS

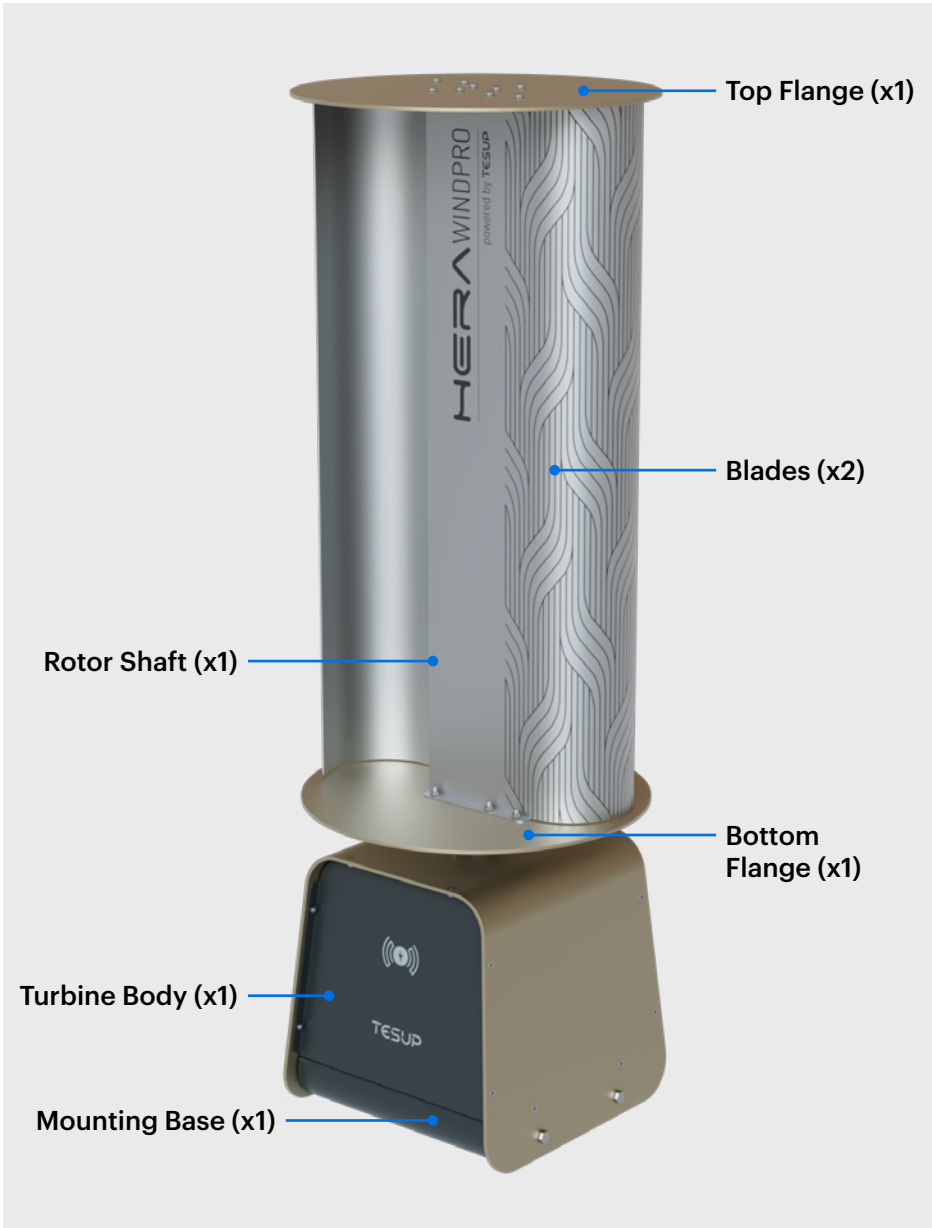

**PARAMETER & DIMENSIONAL DETAILS**

SPECIFICATIONS	
Designation	24V to 48V (Regulated by the Charge Controller)
GENERATOR	
Type	7kW vertical axis wind permanent magnet generator
Weight	24.5 kg (54 lbs)
Max. Power	7kW
Operating Circuit Voltage	0-220V
Current	3-Phase
Start Of Charging	4 m/s
Base Plate Material	Metal
Direction Of Rotation	Clockwise
Test Standards	EN 61000-6-1 (electromagnetic compatibility - immunity) EN 61000-6-3 (electromagnetic compatibility - emissions)
ROTOR BLADES	
Material	Aluminium
Diameter	400 mm (1.31 Feet)
Weight Per Rotor Blades	850 g (1.87 lbs)
Direction Of Rotation	Clockwise
Starting Wind Speed	4 m/s (3 m/s afterwards)
No. Of Blades	2
Max Rpm	950
Max Wind Speed	20 m/s
Noise	35 dB

**POWER CURVE**

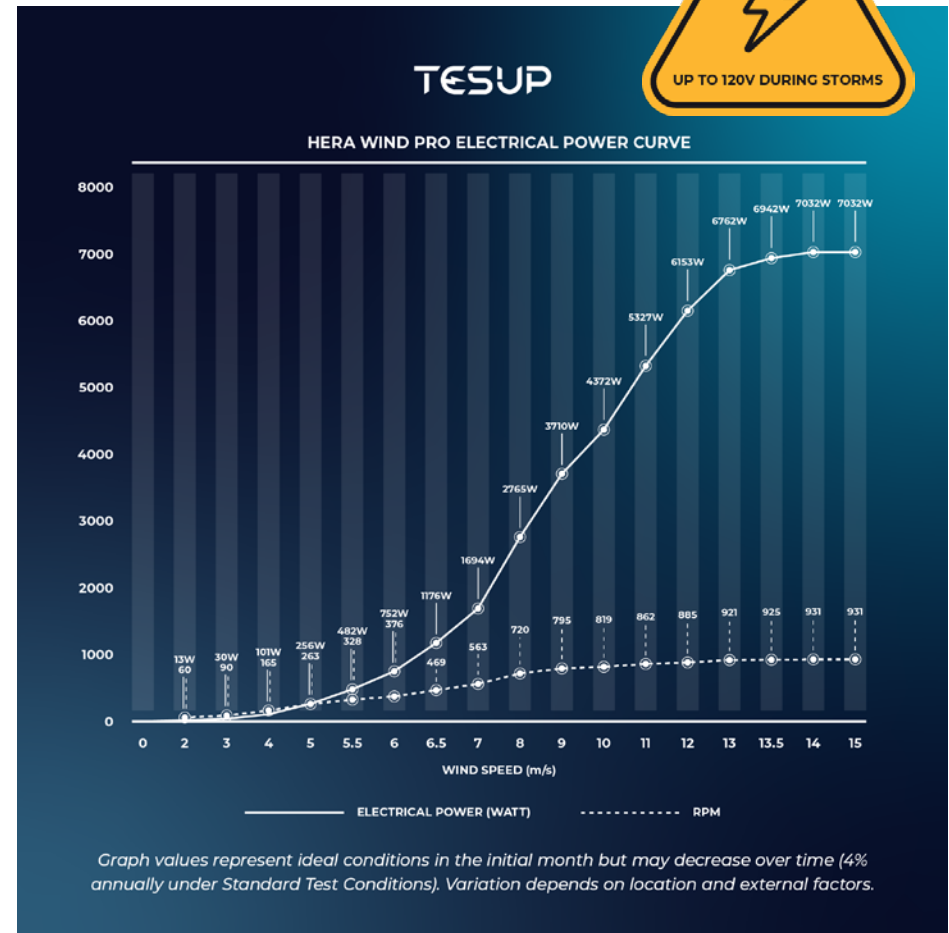

**IMPORTANT:** Humidity, turbulence and the ion levels in the air can impact your turbine's performance.

## GENERAL ARRANGEMENT AND DIMENSIONS

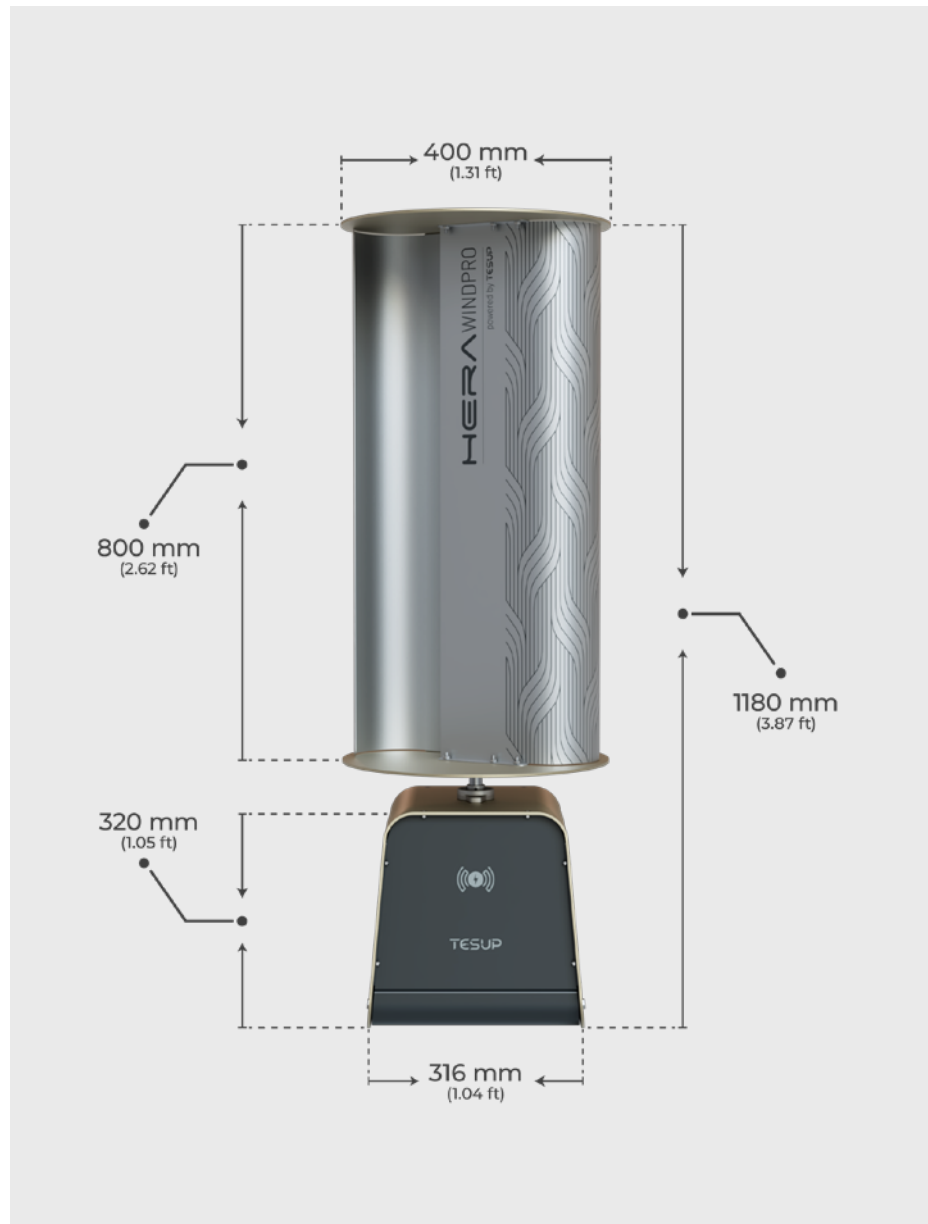

## MOUNTING DETAILS

The mounting surface and bearer selected must be capable of bearing the required load. The size and structure of the foundation should be based on the characteristics of the ground or surface where it will be installed.



**QUICK TIP:** Use of M10 hex bolts or Anchor Fasteners is recommended.



**QUICK TIP:** It is recommended to consult with a qualified structural engineer for advice on determining the optimal mounting surface.



**WARNING:** Before proceeding with wind turbine installation, ensure that the mounting pole is securely fixed to the mounting surface and thoroughly checked for stability.

## ASSEMBLING THE WIND TURBINE

[Click here](#) to watch the HERA WIND PRO turbine assembly video.

Fastening packs available in your package and you will be using for this product's assembly:



1. Carefully open the packaging, taking care not to damage any of the components. After verifying the shipment for completeness, carefully remove all components from the box.
2. Complete the mounting base installation to the turbine's final location as instructed (Use pack D).



**WARNING:** The mounting base of the wind turbine must be fixed to the mounting surface and checked that it is fully stable, before moving on to the next steps with wind turbine installation.



3. Fix the turbine body to the turbine's mounting base.

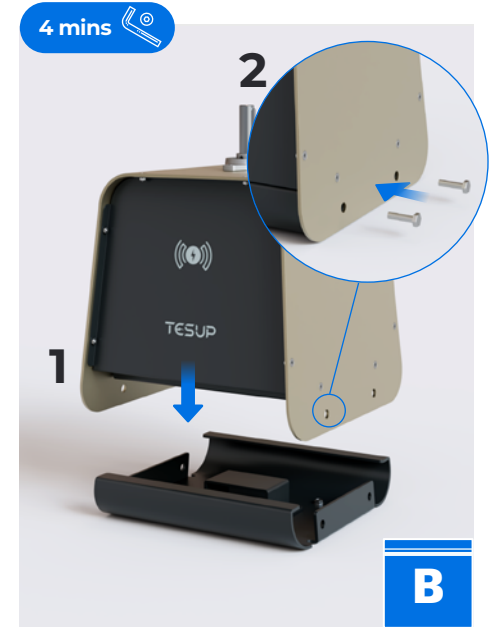

4. Now insert the shaft on the rotor shaft (Triple holes of the shaft should be facing downwards, single hole upwards).



5. Fix the upper body to the base using the grub screws provided.

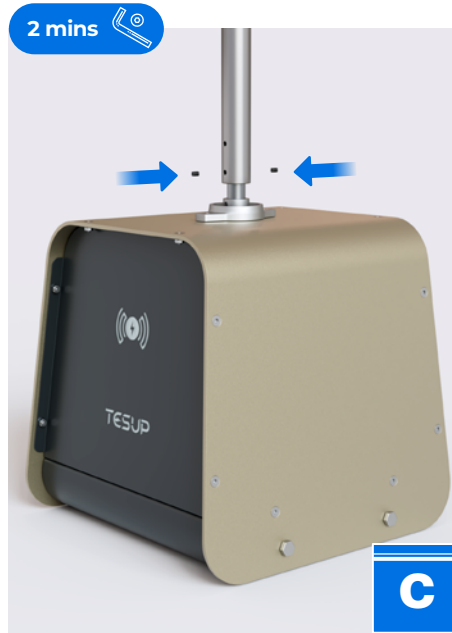

7. Mount the top flange to the shaft.



6. Mount the bottom flange to the shaft.



8. Place the blades between the flanges.

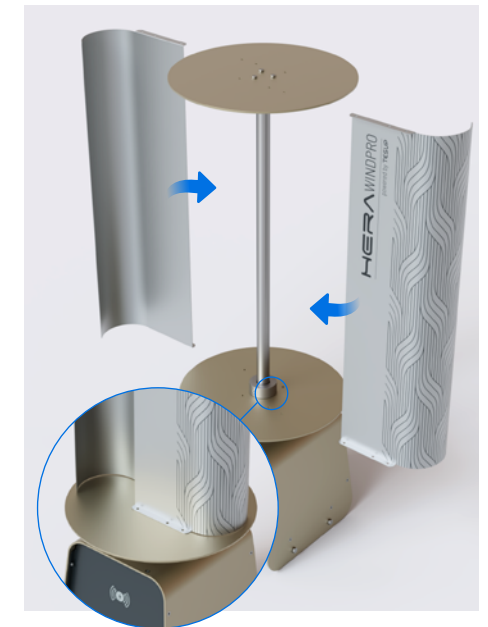

9. Fix the blades to the bottom flange with the use of fasteners provided.

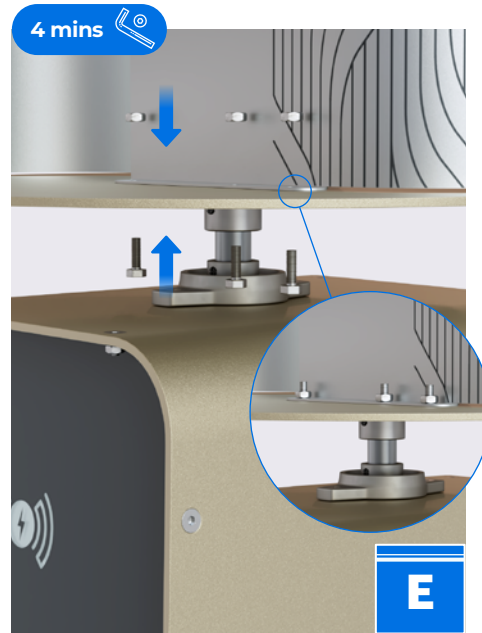

10. Fix the blades to the top flange with the use of fasteners provided.

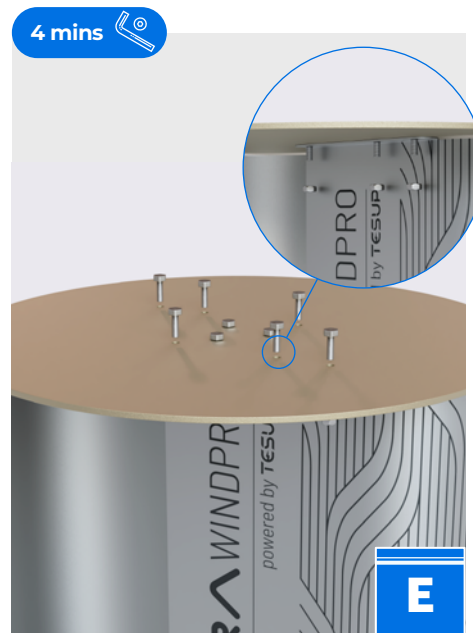

11. Connect the 3-phase AC output terminals located at the wind turbine output to the charge control unit with battery-inverter input, ensuring tight screw connections.

12. If you are using your charge control unit in 'Battery' mode, adjust the maximum voltage using the potentiometer on the unit. (The maximum voltage setting is important for system protection and activating the automatic braking system when the wind speed reaches the capacity to produce the predetermined voltage value.)



**IMPORTANT:** Before proceeding, if you are using a charge control unit, ensure that a battery-inverter is installed in it.



**IMPORTANT:** If a short circuit occurs, the turbine will activate its braking system, preventing the blades from turning.



**WARNING:** Incorrect or loose fastening can adversely affect the efficiency of your turbine, potentially causing damage and posing a risk of injury. Ensure that all fasteners are properly tightened.



# Atlas 7

Vertical Axis Wind Turbine

# Atlas 7

## SYSTEM COMPONENTS



## WIND TURBINE COMPONENTS

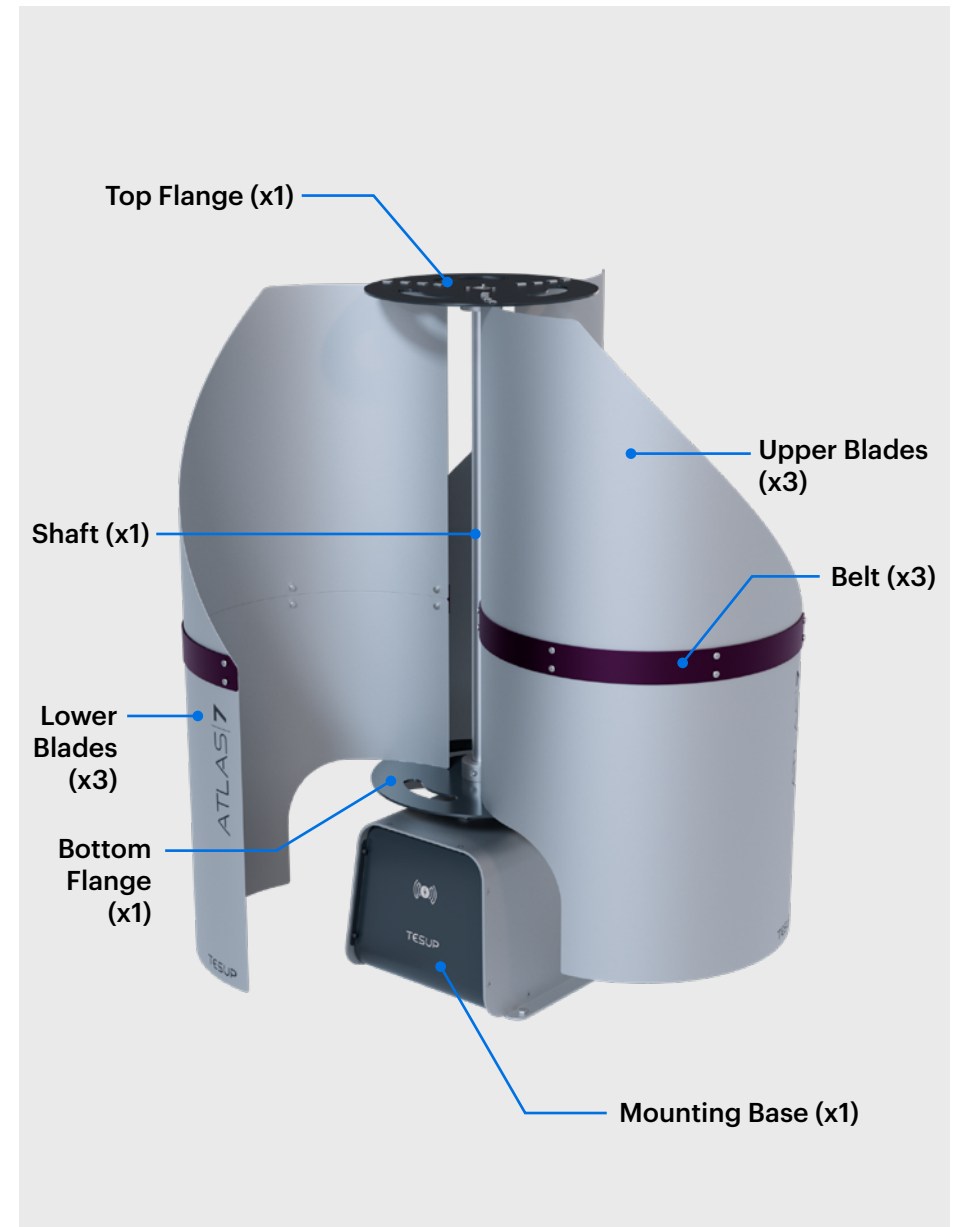

**PARAMETER & DIMENSIONAL DETAILS**

SPECIFICATIONS	
Designation	24V to 48V (Regulated by the Charge Controller)
GENERATOR	
Type	7kW vertical axis wind permanent magnet generator
Weight	24.5 kg (54 lbs)
Max. Power	7kW
Operating Circuit Voltage	0-220V
Current	3-Phase
Start Of Charging	3 m/s
Base Plate Material	Metal
Direction Of Rotation	Clockwise
Test Standards	EN 61000-6-1 (electromagnetic compatibility - immunity) EN 61000-6-3 (electromagnetic compatibility - emissions)
ROTOR BLADES	
Material	Aluminium
Diameter	1200 mm (3.93 Feet)
Weight Per Rotor Blades	750 g (1.65 lbs)
Direction Of Rotation	Clockwise
Starting Wind Speed	4 m/s (3 m/s afterwards)
No. Of Blades	3
Max Rpm	950
Max Wind Speed	20 m/s
Noise	30 dB

**POWER CURVE**

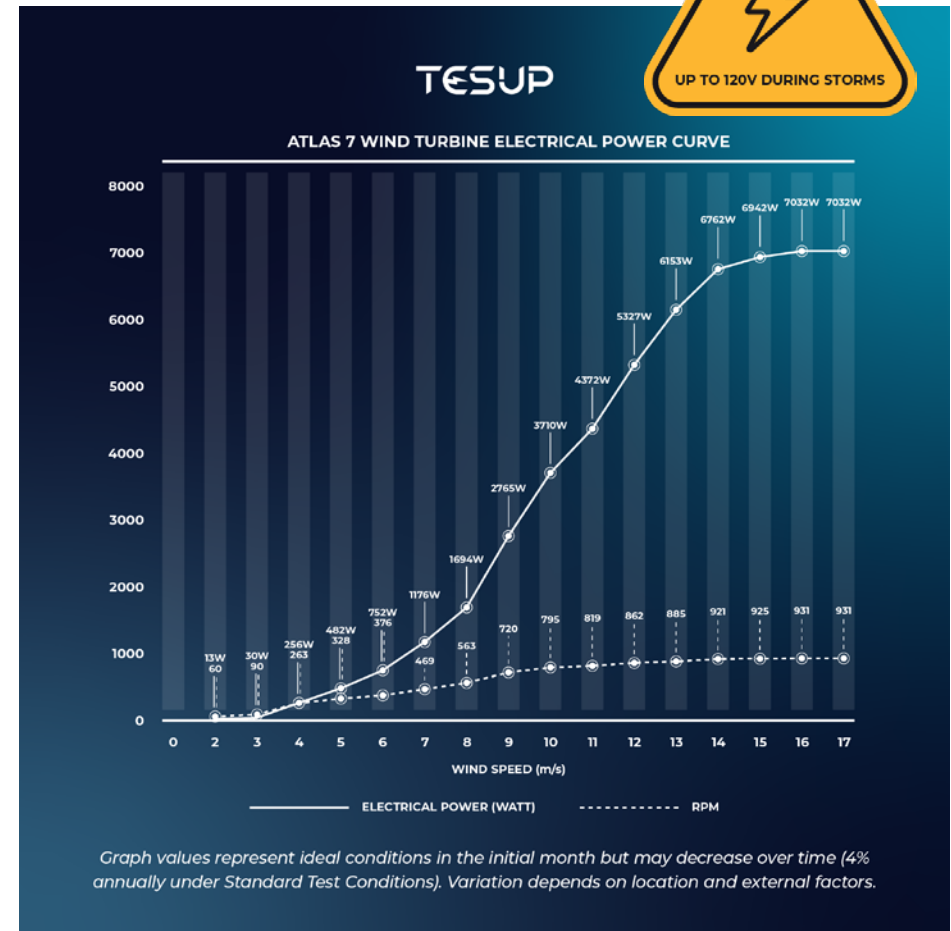

**IMPORTANT:** Humidity, turbulence and the ion levels in the air can impact your turbine's performance.

## GENERAL ARRANGEMENT AND DIMENSIONS

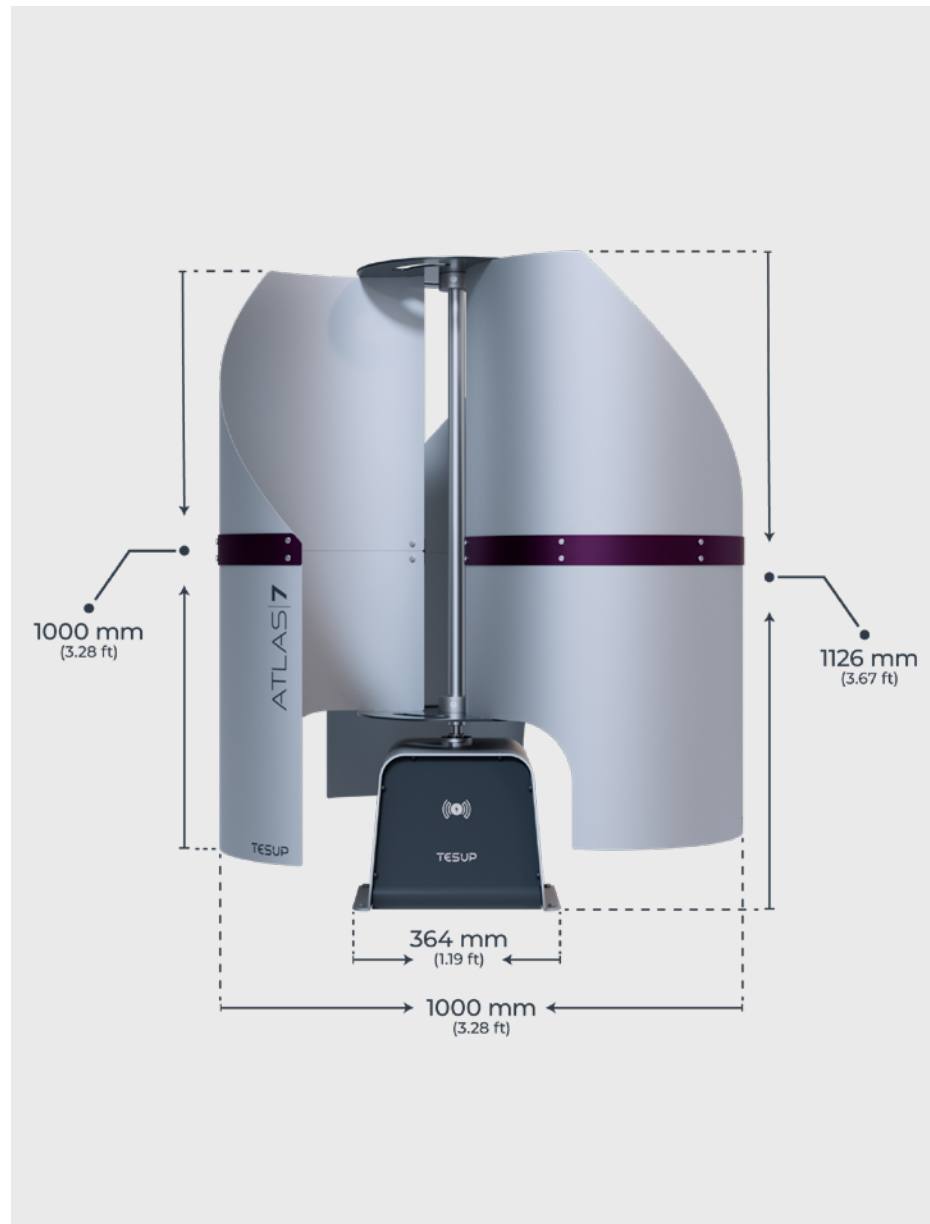

## MOUNTING DETAILS

The mounting surface and the bearer of your choice must have a sufficient load-bearing capacity. The size and structure of the foundation depend on the ground/ surface characteristics.



**QUICK TIP:** Use of M10 hex bolts or Anchor Fasteners is recommended.



**QUICK TIP:** It is recommended to consult with a qualified structural engineer for advice on determining the optimal mounting surface.



**WARNING:** Before proceeding with wind turbine installation, ensure that the mounting base is securely fixed to the mounting surface and thoroughly checked for stability.

## ASSEMBLING THE WIND TURBINE

[Click here](#) to watch the ATLAS 7 turbine assembly video.

Fastening packs available in your package and you will be using for this product's assembly:



1. Carefully open the packaging, taking care not to damage any of the components. After verifying the shipment for completeness, carefully remove all components from the box.
2. Complete the mounting base installation to the turbine's final location as instructed (Use pack D).



**WARNING:** The mounting base of the wind turbine must be fixed to the mounting surface and checked that it is fully stable, before moving on to the next steps with wind turbine installation.

3. Insert the shaft on the rotor shaft (The double holes of the shaft should be on the downside, and the single hole should be on the upside.).

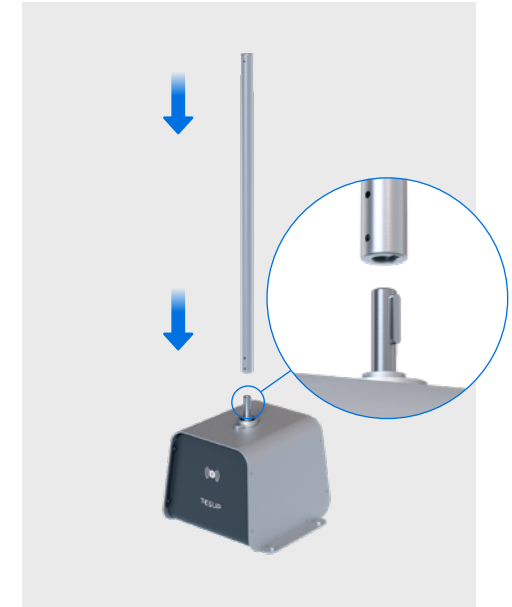

4. Fix the upper body to the base using the grub screws provided.

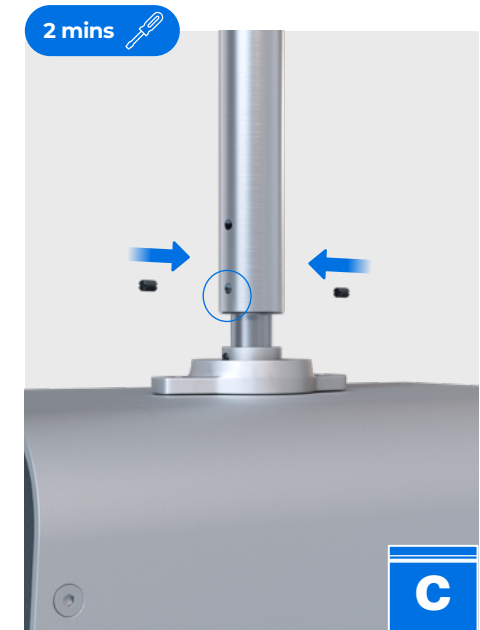

5. Mount the bottom flange to the shaft.

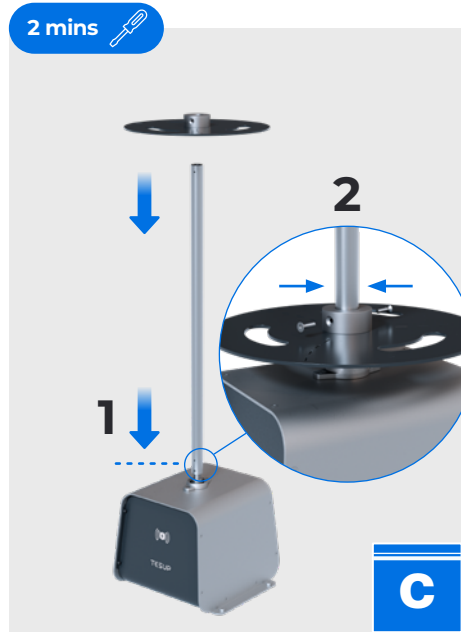

7. Mount the upper and lower blades together via the belt. The belt must be fixed to the blades from the outer surface. Repeat these three steps for all three blade sets.



6. Bring the upper and lower blades together and take the purple belt to connect them.

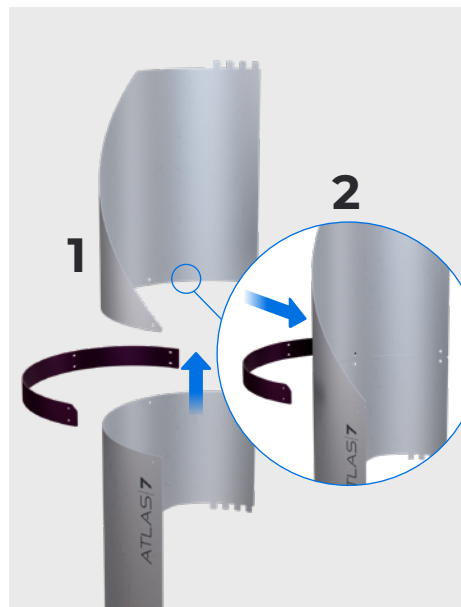

8. Insert the blades into the bottom flange by passing the snaps through the designated housings on the bottom flange.



**9.** Insert the top flange, make sure all the snaps on the blades are passing through the housings on the top flange.

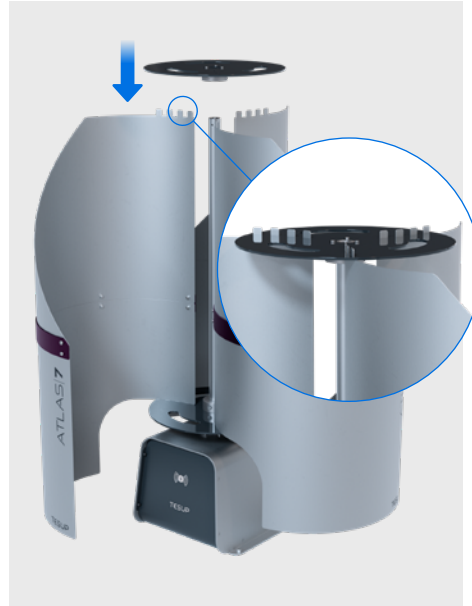

**11.** Carefully bend all the bottom-snaps on the blades using a mallet.

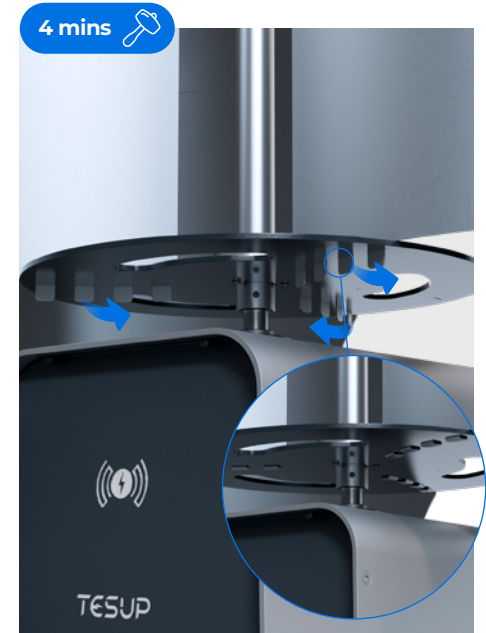

**10.** Mount the top flange to the shaft.



**12.** Carefully bend all the top-snaps on the blades using a mallet.

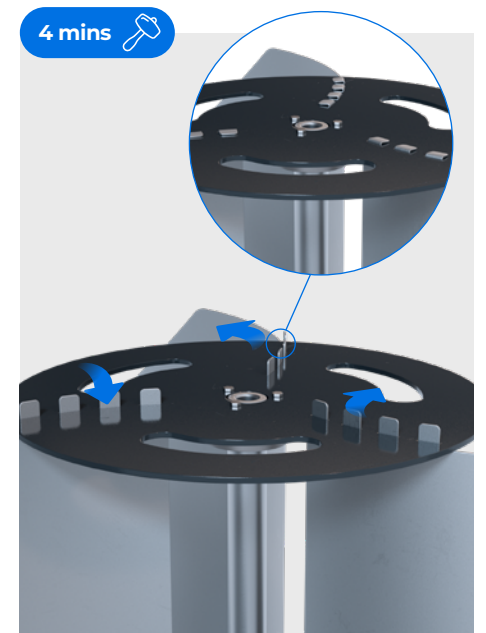



**13.** Connect the 3-phase AC output terminals located at the wind turbine output to the charge control unit with battery-inverter input, ensuring tight screw connections.

**14.** If you are using your charge control unit in 'Battery' mode, adjust the maximum voltage using the potentiometer on the unit. (The maximum voltage setting is important for system protection and activating the automatic braking system when the wind speed reaches the capacity to produce the predetermined voltage value.)



**IMPORTANT:** Before proceeding, if you are using a charge control unit, ensure that a battery-inverter is installed in it.



**IMPORTANT:** If a short circuit occurs, the turbine will activate its braking system, preventing the blades from turning.



**WARNING:** Incorrect or loose fastening can adversely affect the efficiency of your turbine, potentially causing damage and posing a risk of injury. Ensure that all fasteners are properly tightened.



# Atlas X7

Vertical Axis Wind Turbine

# Atlas X7

## WIND TURBINE COMPONENTS

### SYSTEM COMPONENTS

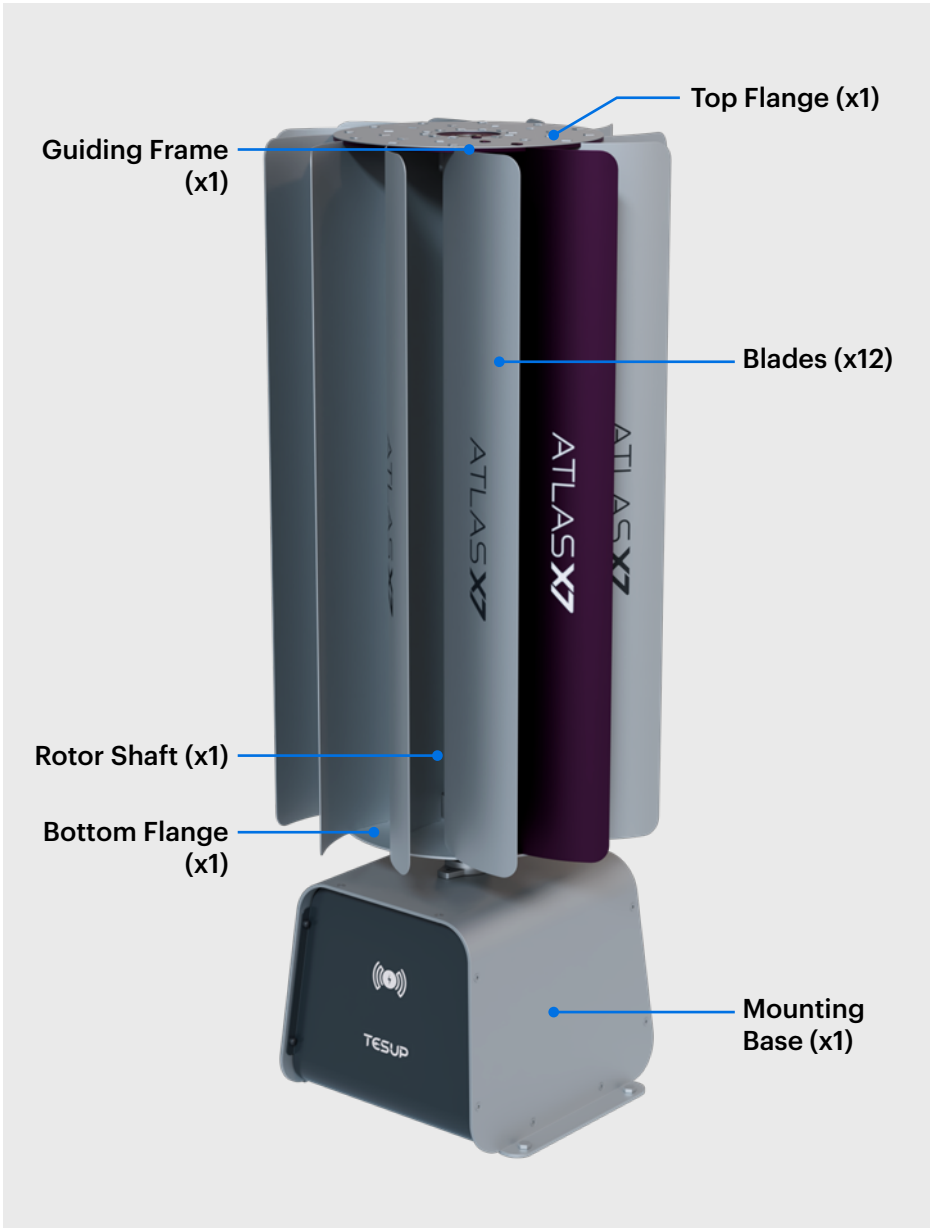

**PARAMETER & DIMENSIONAL DETAILS**

SPECIFICATIONS	
Designation	24V to 48V (Regulated by the Charge Controller)
GENERATOR	
Type	7kW vertical axis wind permanent magnet generator
Weight	24.5 kg (54 lbs)
Max. Power	7kW
Operating Circuit Voltage	0-220V
Current	3-Phase
Start Of Charging	4 m/s
Base Plate Material	Sheetmetal
Direction Of Rotation	Clockwise
Test Standards	EN 61000-6-1 (electromagnetic compatibility - immunity) EN 61000-6-3 (electromagnetic compatibility - emissions)
ROTOR BLADES	
Material	Aluminium
Diameter	460 mm (1.50 Feet)
Weight Per Rotor Blades	100 g (0.22 lbs)
Direction Of Rotation	Clockwise
Starting Wind Speed	5 m/s (4 m/s afterwards)
No. Of Blades	3 or 12
Max Rpm	950
Max Wind Speed	20 m/s
Noise	30 dB

**POWER CURVE**

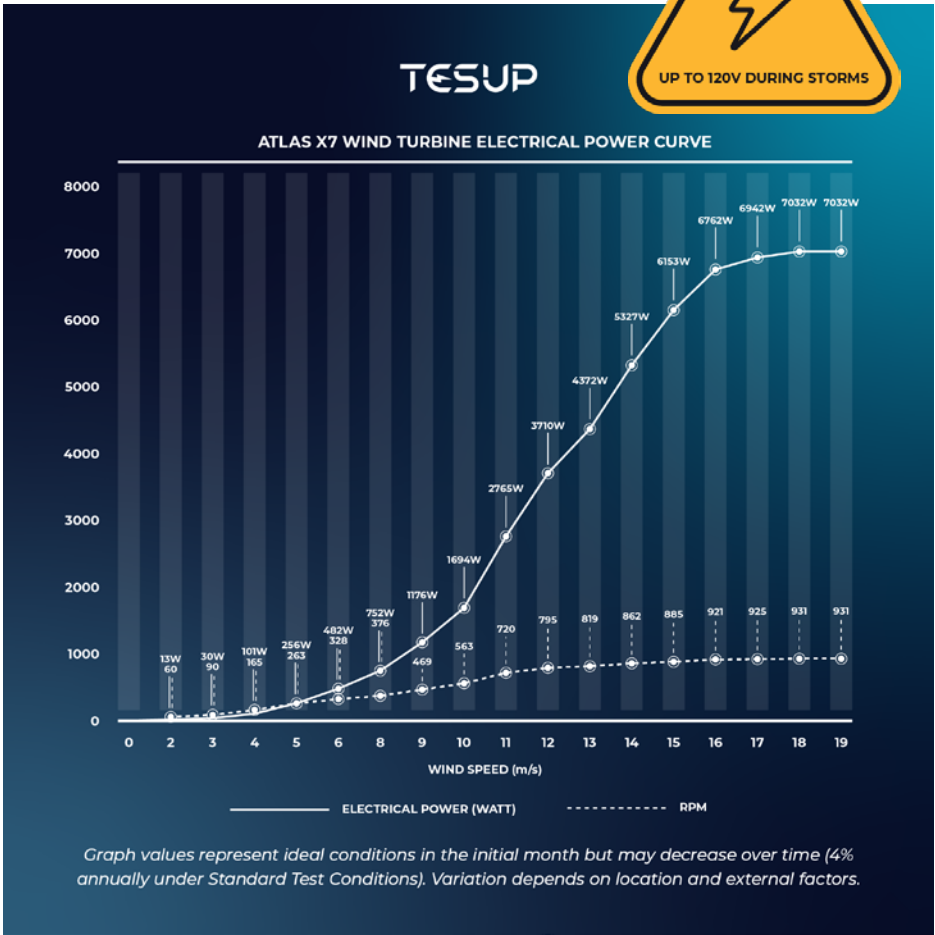

**IMPORTANT:** Humidity, turbulence and the ion levels in the air can impact your turbine’s performance.

### GENERAL ARRANGEMENT AND DIMENSIONS

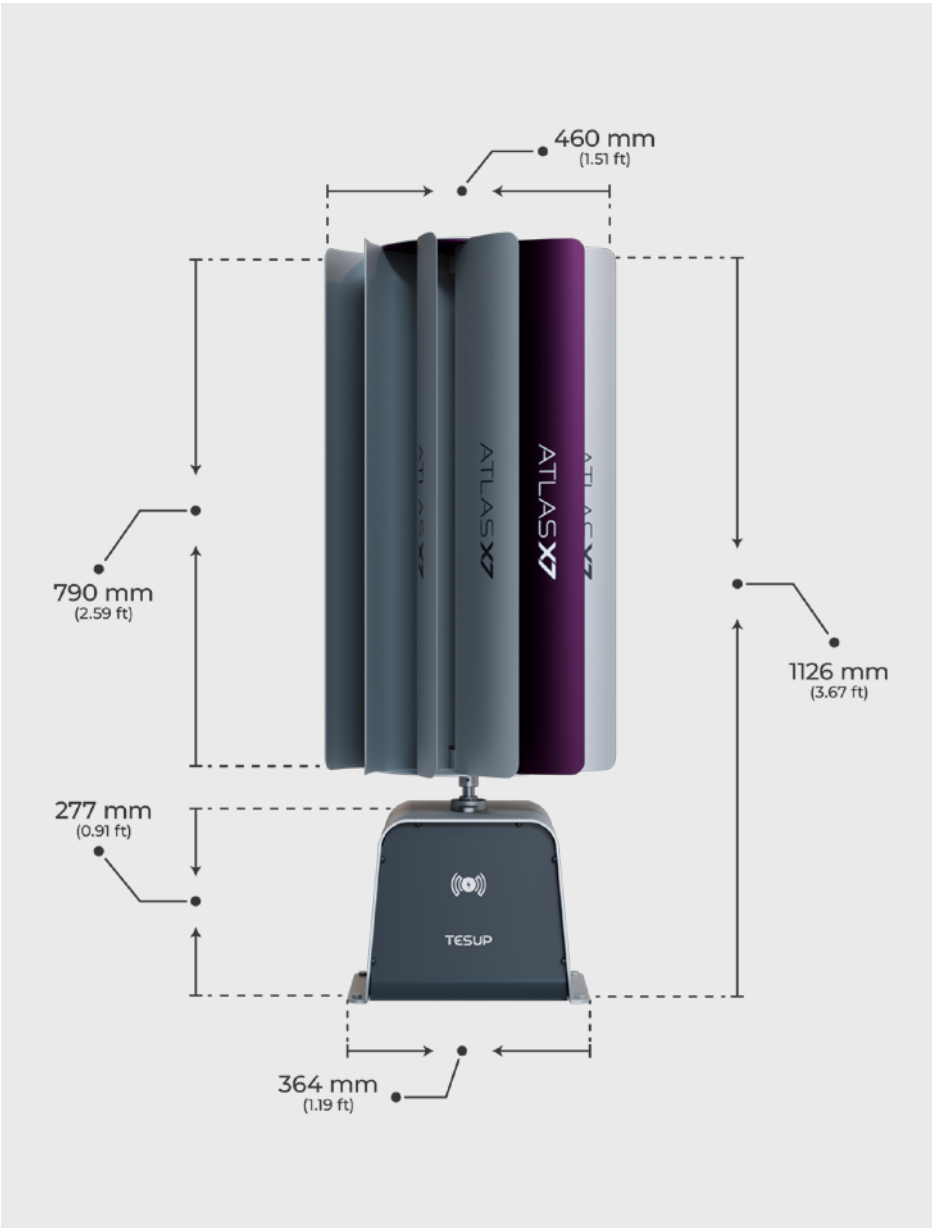



### MOUNTING DETAILS

The mounting surface must have a sufficient load-bearing capacity. The size and structure of the foundation depend on the ground/ surface characteristics.



 **QUICK TIP:** Use of M10 hex bolts or Anchor Fasteners is recommended.

 **QUICK TIP:** It is recommended to consult with a qualified structural engineer for advice on determining the optimal mounting surface.

 **WARNING:** Before proceeding with wind turbine installation, ensure that the mounting base is securely fixed to the mounting surface and thoroughly checked for stability.

## ASSEMBLING THE WIND TURBINE

[Click here](#) to watch the ATLAS X7 turbine assembly video.

Fastening packs available in your package and you will be using for this product's assembly:



1. Carefully open the packaging, taking care not to damage any of the components. After verifying the shipment for completeness, carefully remove all components from the box.
2. Fix the turbine body (mounting base) to the turbine's final location (Use pack D).



**WARNING:** The mounting base of the wind turbine must be fixed to the mounting surface and checked that it is fully stable, before moving on to the next steps with wind turbine installation.



3. Insert the shaft on the rotor shaft (The double holes of the shaft should be on the downside, and the single hole should be on the upside.).



4. Mount the bottom flange to the shaft.

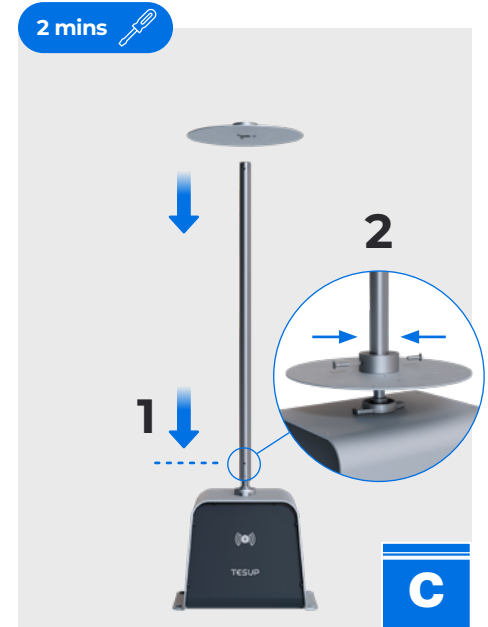

5. Mount the guiding frame to the shaft.



7. Insert the snaps on the blade through the housings on the bottom flange.

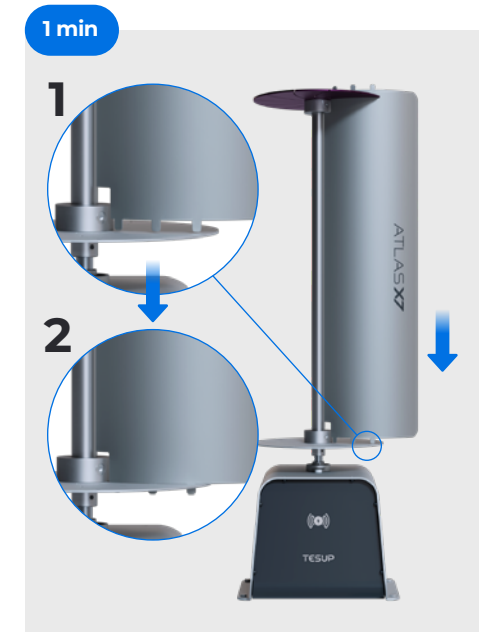

6. Insert the turbine blades into the designated housings on the bottom flange through the guiding frame.

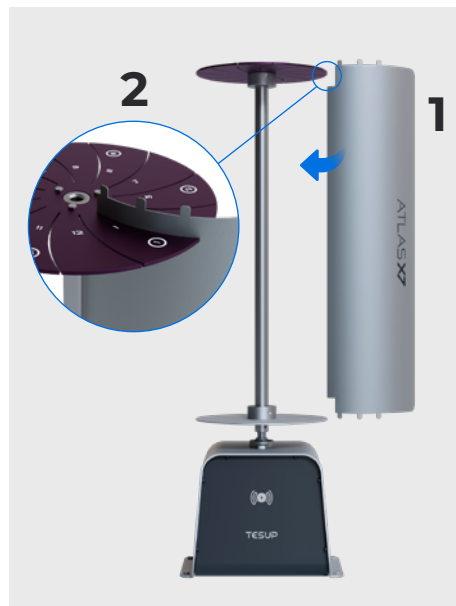

8. Repeat steps 6 and 7 for the remaining blades (3 or 12 blades, depending on the wind speed at the turbine's location).



9. Insert the top flange and ensure that all the snaps pass through the housings on the top flange.

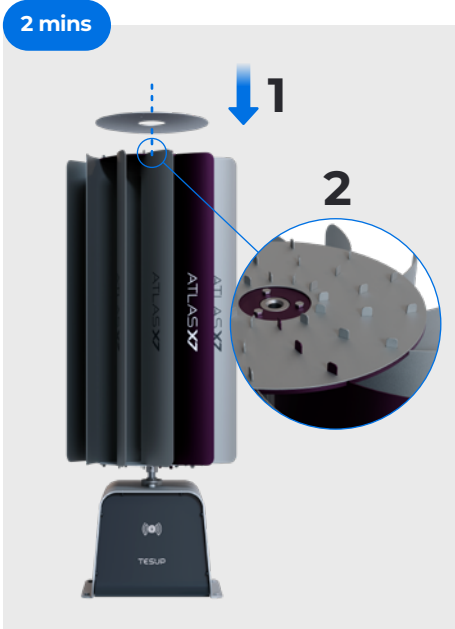

11. Turn the upper body upside down. Holding it from both the top and bottom flanges, carefully place the upper body on a flat surface with the top flange facing the floor.



10. Carefully bend all the top snaps on the blades using a mallet.

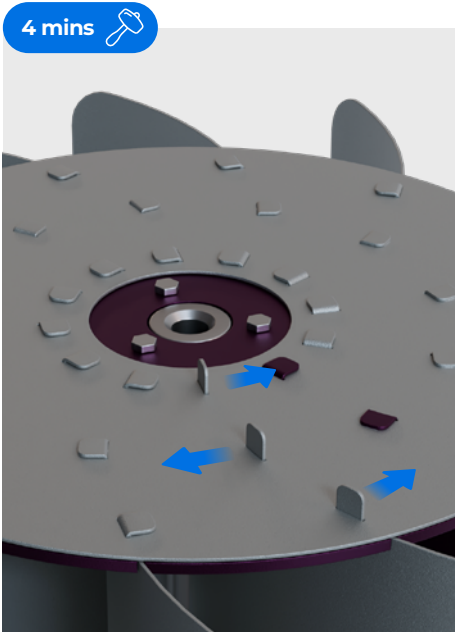

12. Carefully bend all the bottom snaps on the blades using a mallet.

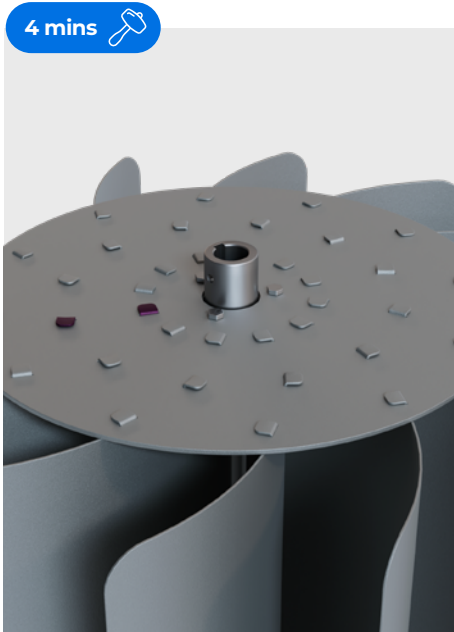

**13.** Flip the upper body, making sure the top flange is facing up again. Insert the shaft on the rotor shaft.



**14.** Fix the upper body to the base, using the grub screws provided.

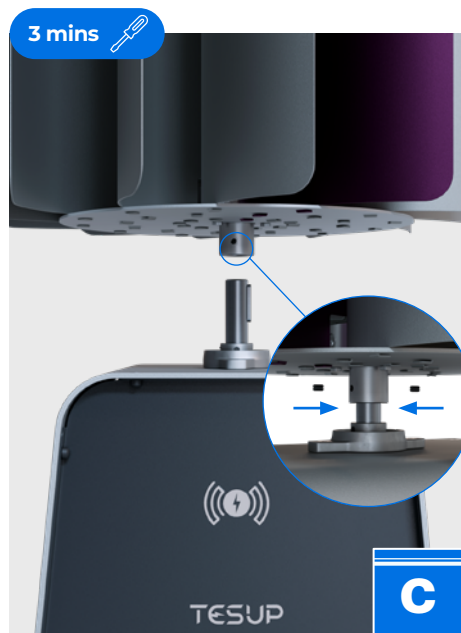

**15.** Connect the 3-phase AC output terminals located at the wind turbine output to the charge control unit with battery-inverter input, ensuring tight screw connections.

**16.** If you are using your charge control unit in 'Battery' mode, adjust the maximum voltage using the potentiometer on the unit. (The maximum voltage setting is important for system protection and activating the automatic braking system when the wind speed reaches the capacity to produce the predetermined voltage value.)



**IMPORTANT:** Before proceeding, if you are using a charge control unit, ensure that a battery-inverter is installed in it.



**IMPORTANT:** If a short circuit occurs, the turbine will activate its braking system, preventing the blades from turning.



**WARNING:** Incorrect or loose fastening can adversely affect the efficiency of your turbine, potentially causing damage and posing a risk of injury. Ensure that all fasteners are properly tightened.



# Master X

Horizontal Axis Wind Turbine

# Master X

## SYSTEM COMPONENTS



## WIND TURBINE COMPONENTS

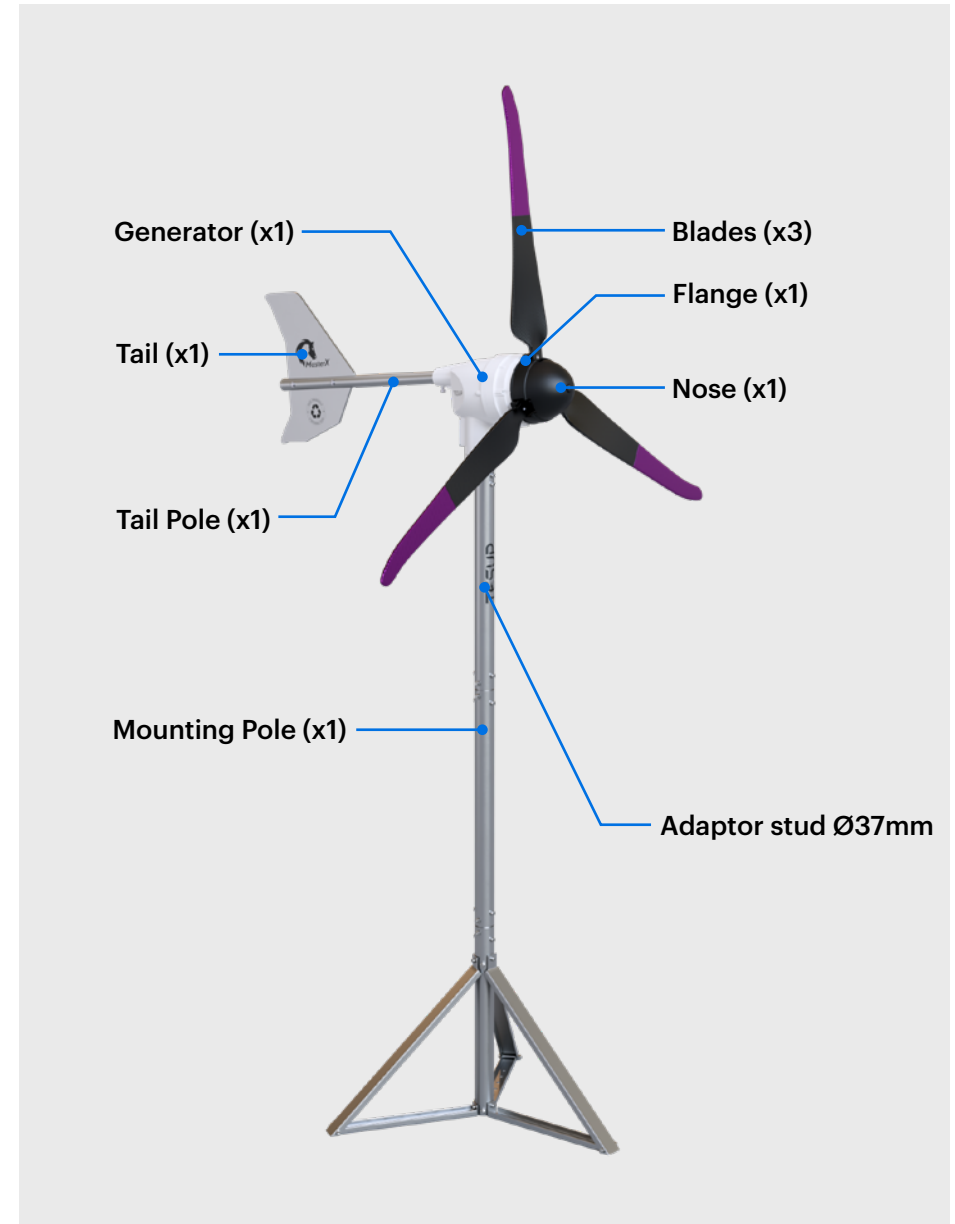

**IMPORTANT:** Please note that the inverter needed for on-grid systems and the charge controller must be supplied separately.

**PARAMETER & DIMENSIONAL DETAILS**

SPECIFICATIONS	
Designation	24V to 48V (Regulated by the Charge Controller)
GENERATOR	
Type	940W horizontal axis wind permanent magnet generator
Weight	9 kg (19.8 lbs)
Max. Power	940W
Operating Circuit Voltage	0-220V
Current	3-Phase
Start Of Charging	3 m/s
Base Plate Material	Aluminium
Direction Of Rotation	Clockwise
Test Standards	EN 61000-6-1 (electromagnetic compatibility - immunity) EN 61000-6-3 (electromagnetic compatibility - emissions)
ROTOR BLADES	
Material	Composite Materials & Cast Aluminium
Diameter	1600 mm (5.25 Feet)
Weight Per Rotor Blades	200 g (0.45 lbs)
Direction Of Rotation	Clockwise
Starting Wind Speed	3 m/s
No. Of Blades	3
Max Rpm	1500
Max Wind Speed	20 m/s
Noise	30 dB

**POWER CURVE**

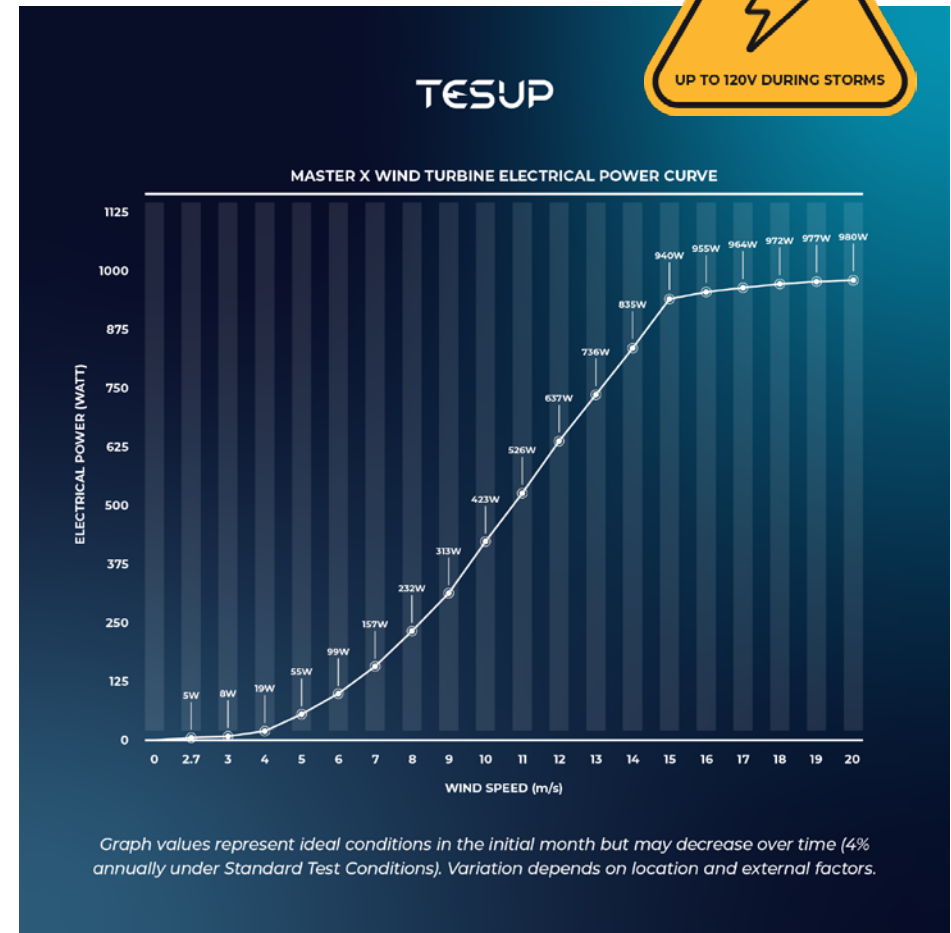

**IMPORTANT:** Humidity, turbulence and the ion levels in the air can impact your turbine's performance.

## GENERAL ARRANGEMENT AND DIMENSIONS

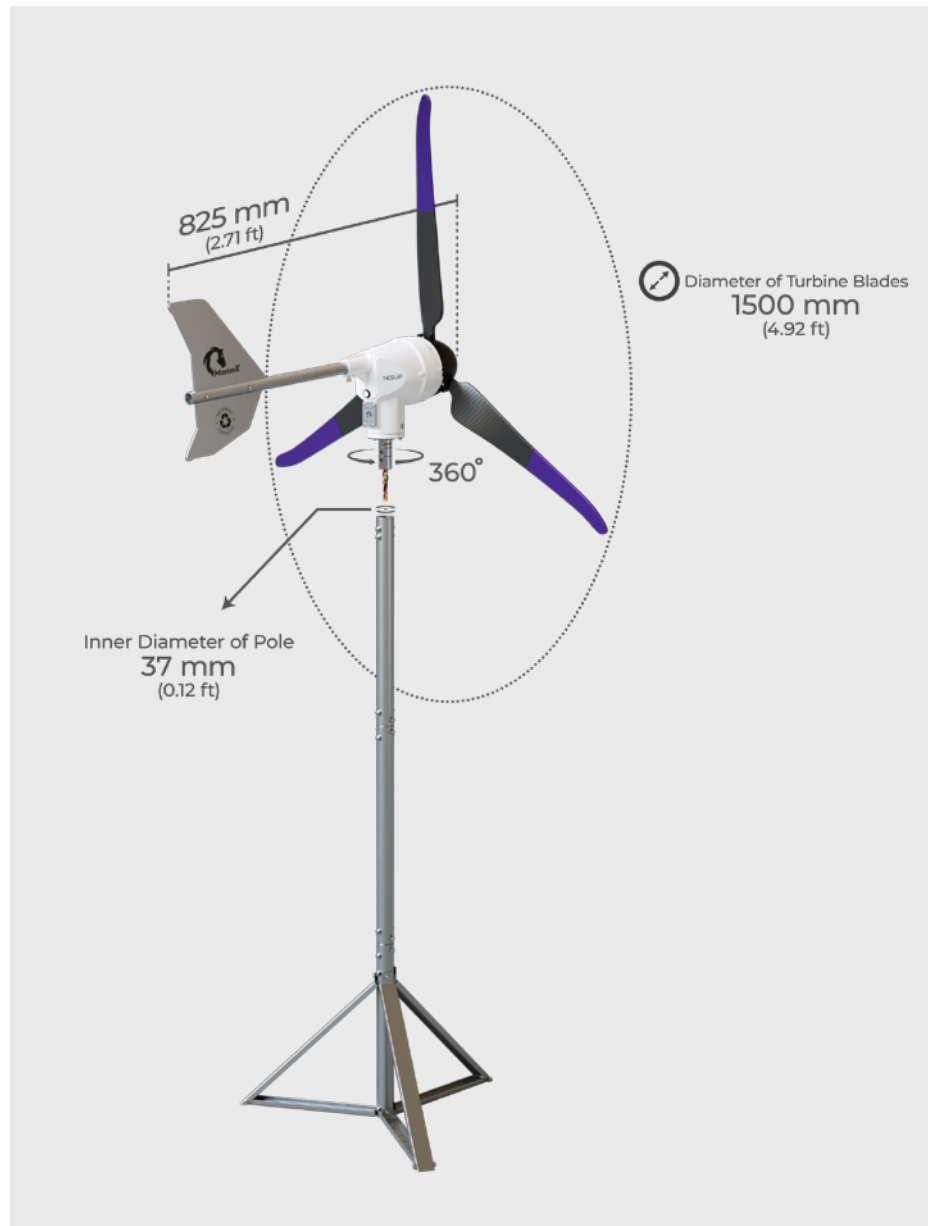

## MOUNTING DETAILS

The mounting surface must have a sufficient load-bearing capacity. The size and structure of the foundation depend on the ground/ surface characteristics.

TESUP mounting pole is designed and developed exclusively for TESUP wind turbines. For technical and safety reasons, we recommend using the Master X wind turbine always with the TESUP mounting pole. Using other types of poles and bearers might cause safety problems and void your warranty.

[Click here](#) to watch the Mounting Pole Assembly video.



**QUICK TIP:** It is recommended to consult with a qualified structural engineer for advice on determining the optimal mounting surface.



**WARNING:** Before proceeding with wind turbine installation, ensure that the mounting pole is securely fixed to the mounting surface and thoroughly checked for stability.

## ASSEMBLING THE WIND TURBINE

[Click here](#) to watch the MASTER X turbine assembly video.

1. Carefully open the packaging, taking care not to damage any of the components. After verifying the shipment for completeness, carefully remove all components from the box.
2. Follow the instructions to complete the installation of the [mounting pole \(MP\)](#).



**WARNING:** The mounting pole must be securely fixed to the mounting surface and thoroughly checked for stability before proceeding with the wind turbine installation.

3. Connect your cable, which will be used to link the wind turbine and the charge controller, to the 3-phase AC output cables at the wind turbine output. Ensure that the connections are properly electrically insulated.

4. Pass the cables you added through the mounting pole (MP), and pull them through the cable outlet.



5. After passing the cables through the outlet, position your MASTER X wind turbine onto the mounting pole (MP) and securely tighten the fixing screws on the mast.

4 mins 



**6.** Insert the tail pole into its designated slot and attach it to the generator.

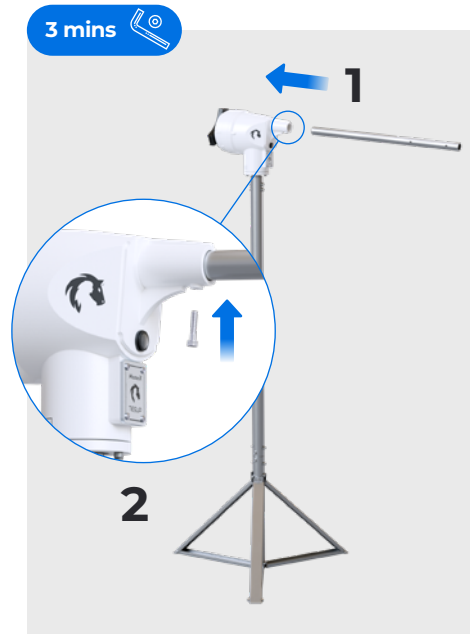

**8.** Follow the instructions to attach and secure the tip and back components of the blades, then place the fixed blades on the flange in any order and screw them correctly.

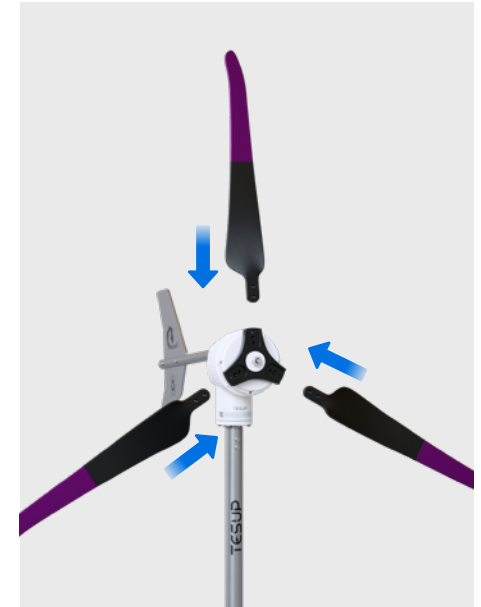

**7.** Place the tail plate into its designated slot at the end of the tail pole and tighten it by screwing it correctly.

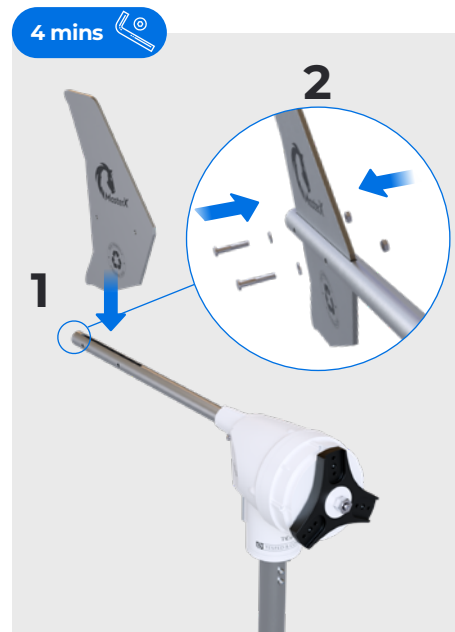

**9.** Attach the fixed unit to the generator.

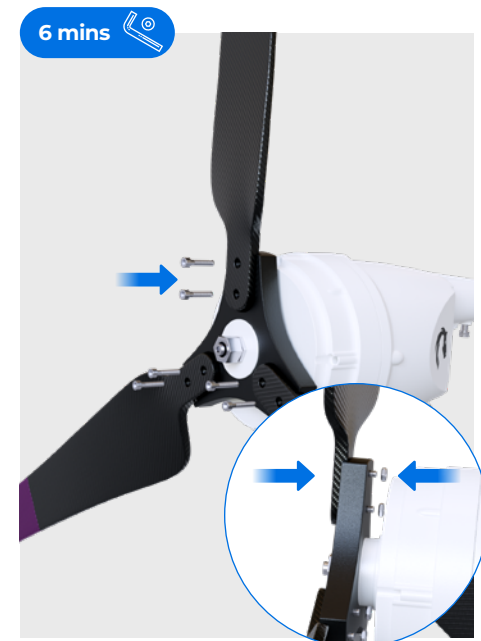

**10.** Place the nose on the flange as instructed, and secure the entire unit to the generator by screwing it through the nose.

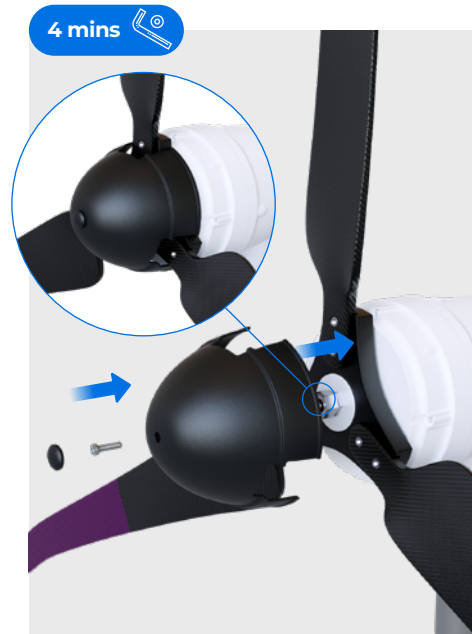

**11.** Connect the 3-phase AC output terminals located at the wind turbine output to the charge control unit with battery-inverter input, ensuring tight screw connections.

**12.** If you are using your charge control unit in 'Battery' mode, adjust the maximum voltage using the potentiometer on the unit. (The maximum voltage setting is important for system protection and activating the automatic braking system when the wind speed reaches the capacity to produce the predetermined voltage value.)



**IMPORTANT:** Before proceeding, if you are using a charge control unit, ensure that a battery-inverter is installed in it.



**IMPORTANT:** If a short circuit occurs, the turbine will activate its braking system, preventing the blades from turning.



**WARNING:** Incorrect or loose fastening can adversely affect the efficiency of your turbine, potentially causing damage and posing a risk of injury. Ensure that all fasteners are properly tightened.



## Charge Controller (Old)

The Wind Turbine Charge Controller from TESUP is an intelligent controller which controls the wind turbine. It safely and efficiently charges and control your battery with the wind generator combination.

With its discreet appearance and simple operation with integrated protection functions, this device has high efficiency and no-load losses. The version of the controller will significantly increase the life and sustainability of all the component of the system.

The special features of TESUP Charge Controller and product information are listed below:

- Use of solid-state components.
- Manual brake function.
- Increasing the life of the controller. Microprocessor controlled charge with integrated voltage and current limiting.
- Dump-load is included. Modern Load dissipation system in three steps to avoid immediate blockage of turbine.
- Resistors might be used for heating.

### PARAMETER DETAILS

Recommended max. battery charging voltage levels are as follows:

SPECIFICATIONS		
12 V	24 V	48 V
13.8 - 14.2 Volts	27 - 28.4 Volts	52 - 58 Volts

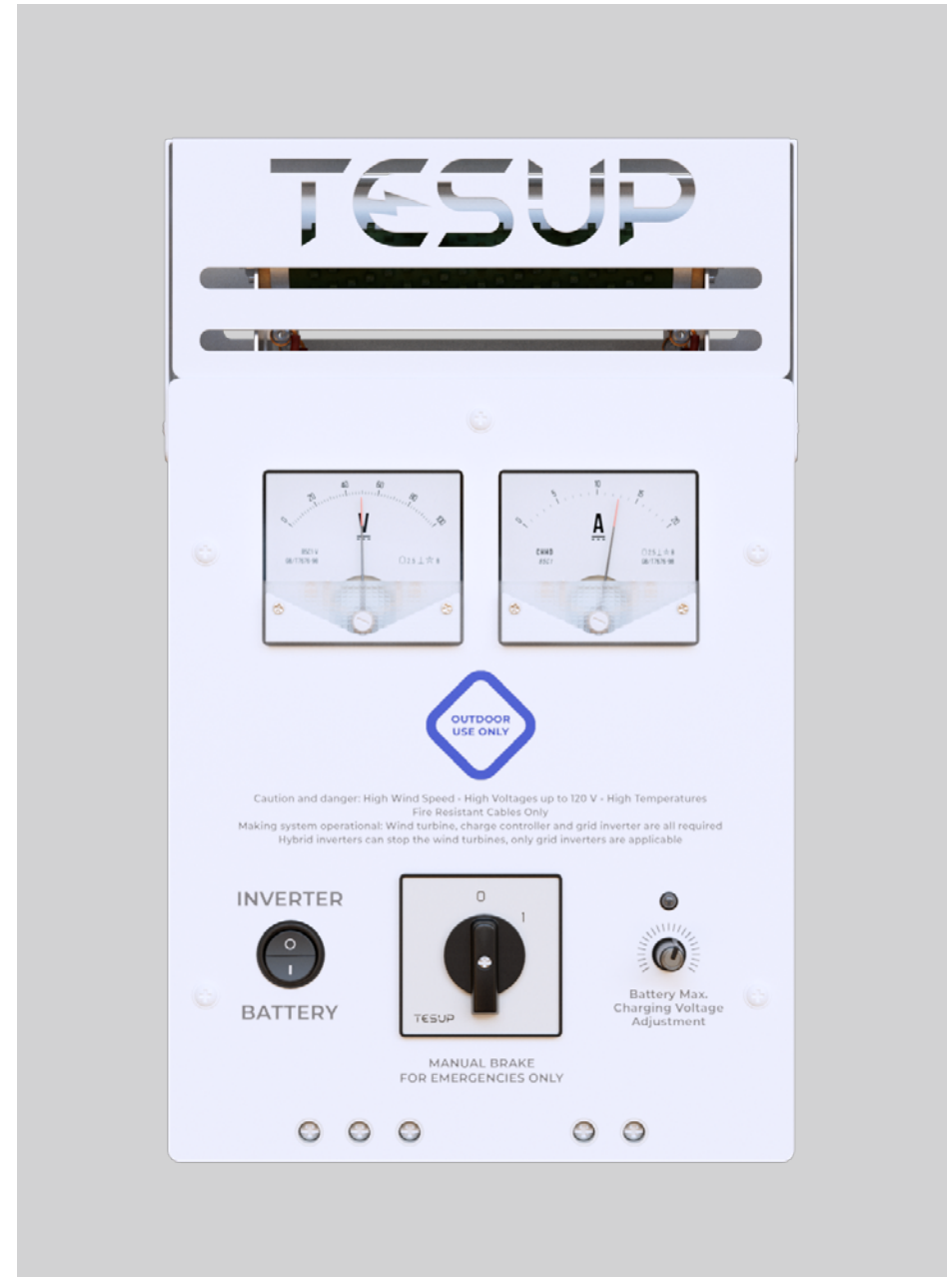

## GENERAL ARRANGEMENT AND DIMENSIONS

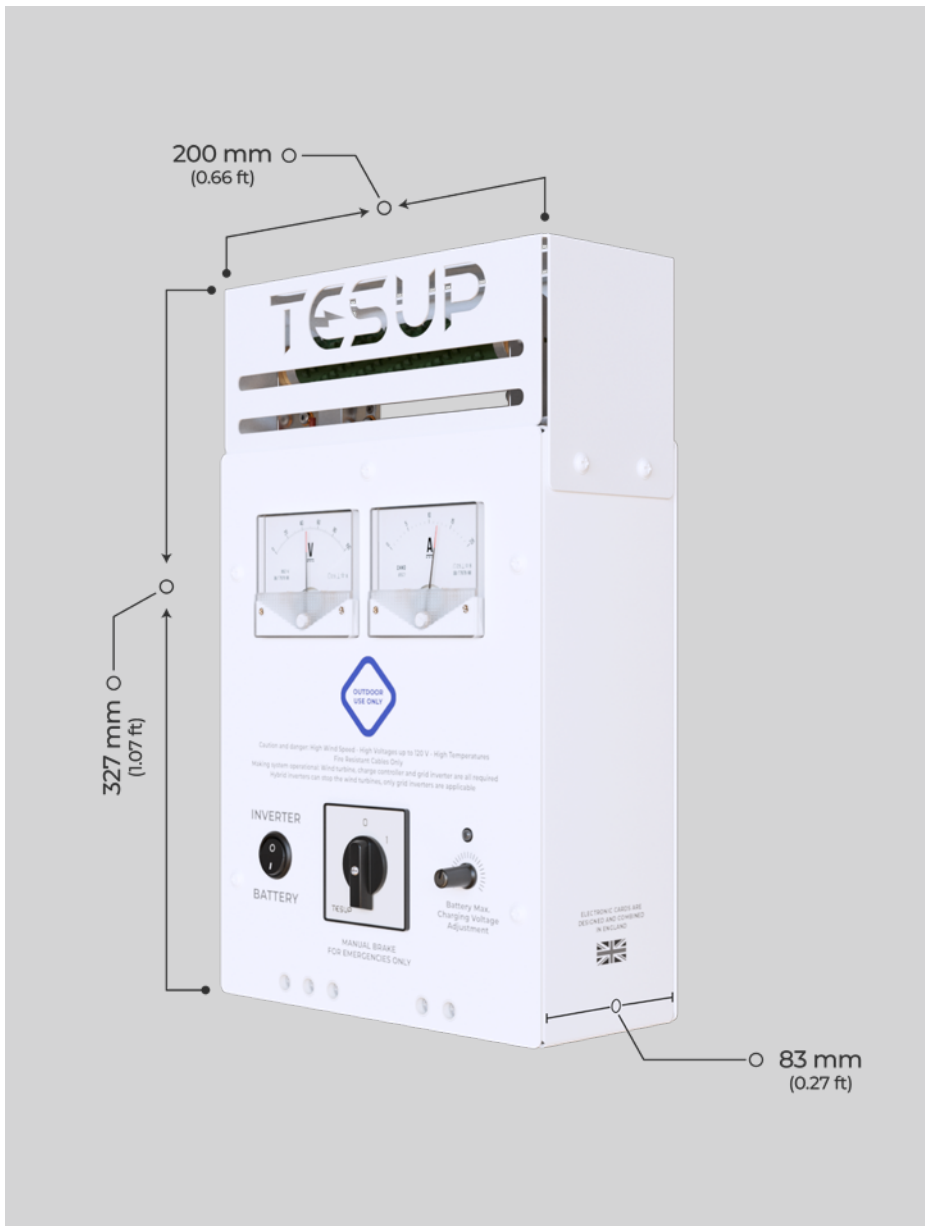

## CHARGE CONTROLLER COMPONENTS

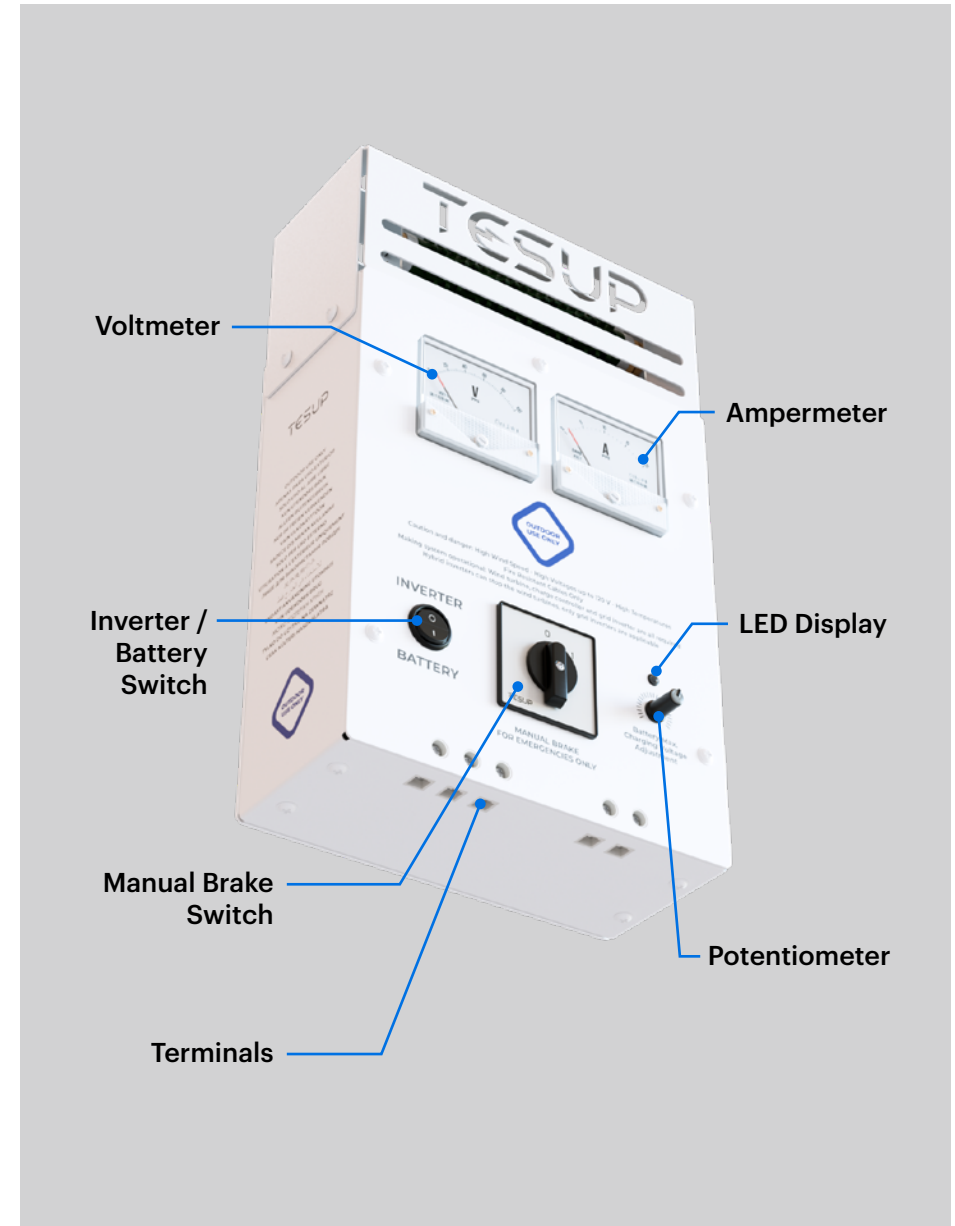

## WIRING DIAGRAMS

The TESUP Charge Controller can be connected in two ways:

**1. On-Grid Systems:** In this setup, the wind turbine is connected to the grid, allowing for the direct feeding of excess energy into the grid.



**IMPORTANT:** Please note that the inverter needed for on-grid systems must be supplied separately.

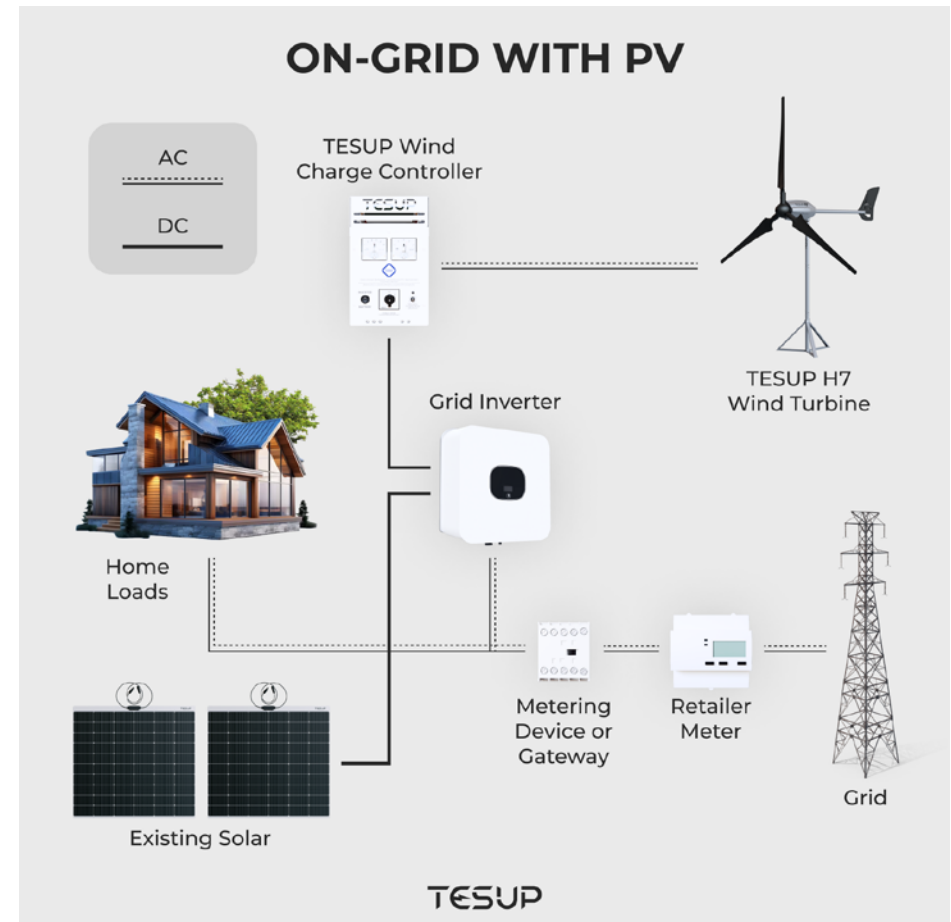
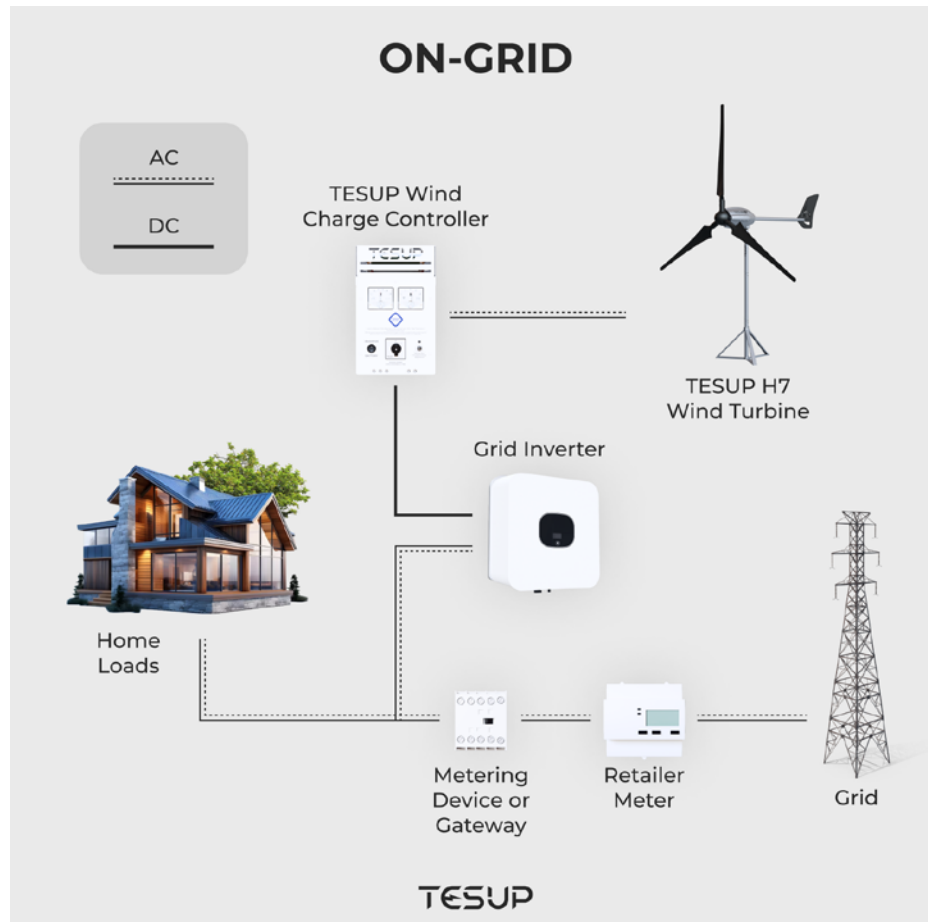

**2. Off-Grid Systems:** This configuration allows for the storage of excess energy generated by the system in batteries for later use.

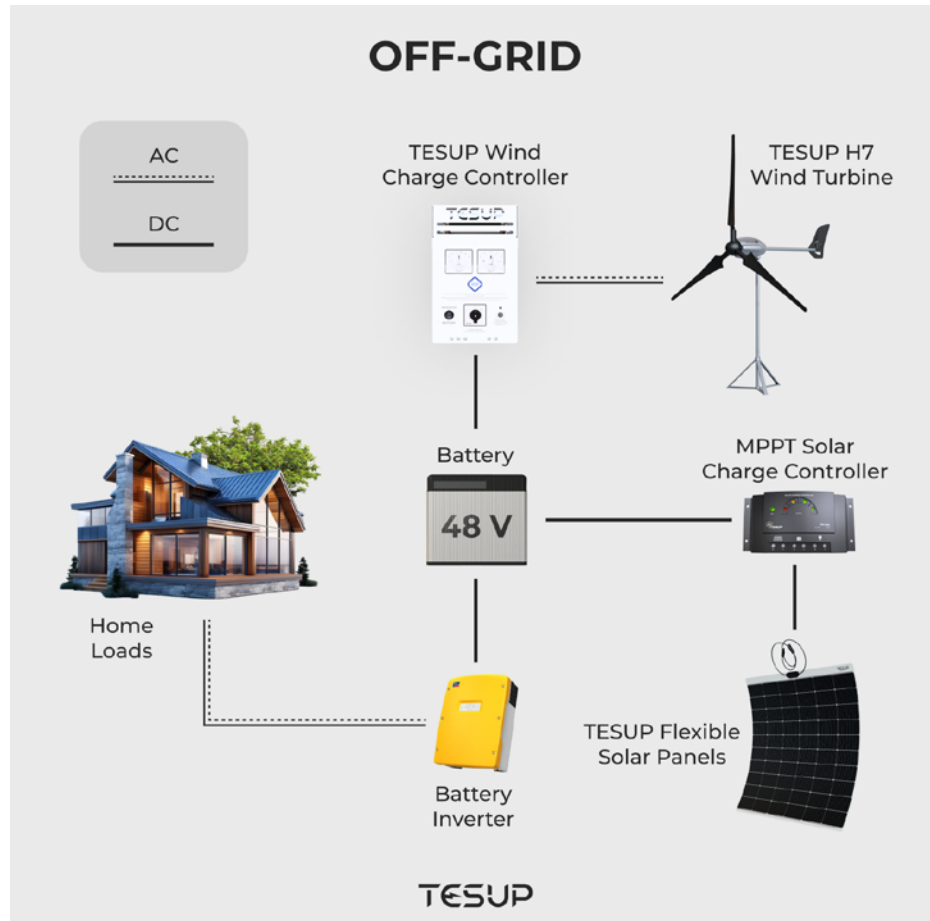

### CONNECTING YOUR WIND TURBINE TO THE CHARGE CONTROLLER

To connect the cables of the wind turbine to the charge controller, follow these steps:

1. Strip the wire coming through the motor and the connecting wires.
2. Secure the wires with a wire nut and wrap electrical tape around each wire.
3. Insert the wire into the controller and then tighten the screw. Repeat this step for the remaining wires.
4. When connecting directly to batteries, or to an inverter for AC power, insert the wire into the appropriate connectors, ensuring to match the positive and negative indicators.
5. Connect the other end of the wire to the battery or the inverter and secure it using a suitable cable gland or sleeve.
6. Finally, connect the AC power cable.

[Click here](#) to watch a video showing the cable connections.

Check [Regular Operation](#) section for controlling your wind turbine.



**IMPORTANT:** Wind turbine is turned on once the brake is switched off.



**WARNING:** To operate the system, the TESUP Wind Turbine, TESUP Charge Controller, and an inverter are all required and must be installed outdoors in a dry location.



**WARNING:** Exercise caution when connecting wind turbines to charge controllers. Ensure proper alignment and secure attachment of cables, wires, and connectors for efficient operation.



# Frequently Asked Questions

# Wind Turbines

- **What are the differences between horizontal and vertical wind turbines?**

The most significant differences between horizontal- and vertical-axis wind turbines are as follows:

1. A horizontal-axis wind turbine has its axis of rotation parallel to the wind stream, whereas a vertical-axis wind turbine has its axis of rotation perpendicular to the wind stream.
2. Horizontal-axis wind turbines usually use three blades, whereas vertical-axis wind turbine configurations, blade shapes and the number of blades vary a lot.
3. Horizontal-axis wind turbines pivot facing the direction of the wind. Whereas vertical-axis wind turbines are omnidirectional, they do not change orientation to match the wind direction.

- **Which one is a better option, horizontal or vertical wind turbine?**

Both turbine designs have their advantages.

Vertical-axis wind turbines are more indicated when it comes to residential applications. They are easier to install and require less space. They don't have to be facing the right wind direction either. In a vertical system, air flowing from any direction can rotate the blades. They also handle turbulent winds better than horizontal wind turbines.

Horizontal-axis wind turbines have higher efficiency ratings and are more likely to operate at higher wind speeds. They are better at converting wind energy into useful mechanical motion because their blades are perpendicular to wind direction, so energy can be generated the entire way through the rotation.

You can make your decision depending on where you plan to install your wind turbine, how much space you have and how much energy you plan to generate.

- **What are the differences between ATLAS and ATLAS X models? Which performs better?**

Both ATLAS models are very robust, compact, and durable yet lightweight.

ATLAS 7 can generate up to 7 kWh of electricity per hour. Its rotation starts at 4 m/s wind speed. Rotation and power generation start at even 3 m/s wind speed. It starts rotating at a lower wind speed as a result of its larger blades. It's larger in size and occupies more space.

ATLAS X7 can generate up to 7 kWh of electricity per hour. Its rotation starts at 5 m/s wind speed. Rotation and power generation start at even 4 m/s wind speed. It is more compact than ATLAS 7.

- **Can I connect my TESUP Wind Turbine to a battery?**

Yes, you should connect your TESUP Wind Turbine to the TESUP Charge Controller first, then link TESUP Charge Controller to your battery. TESUP Charge Controller is required to convert AC (Alternative Current) to DC (Direct Current) and control battery charging.

- **Is it possible to connect multiple wind turbines in one system? If YES, how?**

Yes, it is possible to connect multiple wind turbines in one system. We recommend a parallel connection of every TESUP Wind Turbine to your home electricity board. Every TESUP Wind Turbine should be connected to a separate TESUP Charge Controller which should be connected to a separate inverter. Then different inverters should be connected to your home electricity board. This is our recommendation and the safest

method to make sure that every wind turbine can operate independently from each other and that the system can continue to generate energy in case of a product-specific problem.

- **How noisy are TESUP Wind Turbines? What are the noise level measurements?**

All of our wind turbines are very quiet, producing only up to 40 dB, which is less than half the sound of a vacuum cleaner. Noise levels of our products are regularly checked and tested in ideal outdoor environments for wind turbine installation.

- **Are all TESUP Wind Turbines tested? How can I know if my turbine is tested or not?**

Every TESUP Wind Turbine is tested before its packaging process at our factory. A video recording happens during every product's test process that shows the product's serial number in a visible way. These test videos are shared with the customers just after the product delivery.

- **Can I use my solar panel and wind turbine together in the same energy system?**

Yes, you can. The systems combining solar panels and wind turbines are called Hybrid Systems. Different connections and components are required for the off-grid and on-grid systems.

For the off-grid solution: The wind turbine is connected to the wind turbine charge controller that is connected to the battery. The solar panel is connected to the solar charge controller that is connected to the same battery. The battery is connected to the battery inverter that is connected to home loads or electric vehicles for electricity consumption.

For the on-grid solution: We recommend a full parallel connection of

wind turbine and solar panel unless you have a very good quality 2 MPPT inverter. The wind turbine is connected to the wind turbine charge controller which is connected to a grid inverter. The solar panel is connected to a different grid inverter to ensure maximum efficiency of the entire system. Both grid inverters are connected to the home separately for electricity usage. They're also connected to the grid via the metering device and retailer metre to feed the extra electricity back into the electrical grid network.

See the detailed off-grid and on-grid system diagrams for [V7](#) and [H7](#).

- **There is a vibration when my TESUP Wind Turbine rotates. Why?**

All screws, bolts, and mounting parts of the turbine system must be mounted correctly and securely during the installation. Additionally, the mounting base of the turbine must be fixed to the mounting surface properly and checked that it is fully stable. Otherwise, vibration may occur.

Please check the screws and bolts on your wind turbine system at least every 6 months to make sure they are properly fastened.

- **What are the recommended minimum and maximum heights to install a TESUP Wind Turbine?**

Minimum and maximum height requirements change from country to country. But as a general direction, the distance between ground level and the lowest part of any wind turbine blade should not be less than three metres. And the highest part of the stand-alone wind turbine shouldn't exceed 11 metres. These are the average limits to follow in most countries. We highly recommend you check the specific requirements in your country.

The placement of your vertical and horizontal wind turbines can have a large effect on how much power they generate. We recommend you

place your TESUP Wind Turbine as high as possible, ideally on the roof of a building or on a standalone pole. Wind speed is the lowest on the ground level so making sure that the turbine is as high up as possible will maximise the rotation speed and power generation. A horizontal wind turbine should not be placed behind obstacles (like buildings or trees). If there is an obstacle, the turbine can be placed on a pole to ensure its level is much higher than the obstacle.

- **How can I reach maximum efficiency with my wind turbine?**

The amount of power that can be extracted from the wind depends on the speed of the wind and the size of the turbine blades. No wind turbine is 100% efficient (even when running at its optimum wind speed). There is friction between all the moving parts, and some power is lost at the gears or different connection parts of the system, and this is normal. You can use the TESUP Power Curve Chart included in the user manual in order to calculate the true output for the average wind speeds on your site. This allows you to see the estimated power output at your local wind speed.

In order to make the system operational and reach the estimated power output, TESUP Wind Turbine, TESUP Charge Controller, and a grid inverter are all required. Please note that the inverter needed for on-grid systems must be supplied separately. Additionally, you must make sure that your turbine system is installed by a professional electrician, fixed securely to the mounting surface, and adjusted according to the wind direction.

- **Why is the voltage of my wind turbine low?**

There are many reasons why the turbine may be demonstrating lower outputs than anticipated. These reasons can stem from turbulence and erroneous measurements through battery type and condition. Turbulence is the most common reason why turbines do not perform to their specification. Cable size may also affect the output. Ensure that the correct minimum and maximum cable sizes are installed. Different

battery technologies, battery age, and conditions will also affect the rate at which the batteries can absorb power. Last but not least, measurement errors may occur easily while measuring the wind and power output of the turbine. Ensure that high-quality shunts are employed for accurate current readings.

- **I can't get current from my wind turbine. Why?**

The turbine may be running in an off-load state, meaning that the circuit from the turbine to the batteries is incomplete. In this situation, the turbine is free spinning and may generate higher voltages than anticipated from the turbine output cables. Check that all of the connections from the turbine through the run/stop switch and the batteries are correct. If a fuse or circuit breaker has been fitted to the turbine, ensure that this is correctly closing the circuit. Never leave the turbine running in an off-load state, as it may cause damage to the turbine during high winds.

- **Something is stopping my wind turbine; it was working well before. What might be the problem?**

There are a few reasons that might cause this issue:

1. If the wind turbine is connected to a battery, the charge controller stops the wind turbine once the battery is full to the adjusted maximum charging voltage level.
2. If two or more cables are touching each other we call it short-circuit. The short-circuit can stop the electricity flow and this might be a reason. Please control all cables and be sure they are not touching each other.
3. There are some cheap hybrid battery inverters in the market. There are battery inverters and solar charge controllers combined but these cheap hybrid charger inverters are acting as solar charge controllers at first. These devices can stop the wind turbines via the battery.

4. Limit voltage adjustment with the potentiometer may be wrong. If the led lights up, it means it is braking. If the potentiometer is set incorrectly, the turbine will brake in order not to exceed the determined voltage.
5. The switch on the Charge Controller can be in position 1.
6. Our system is integrated into the end consumption point. The TESUP Charge Controller converts produced energy to heat in dangerous situations(dump-load system). But, the fuse connection prevents this. That's why customers shouldn't use a fuse connection between the wind turbine-charge controller-inverter connection.

• **I think my wind turbine is not rotating freely. What could be the reason?**

TESUP wind turbines have permanent magnet generators having strong N42 neodymium magnets with steel slots inside. These wind turbines are designed for maximum power performance. When the wind speed is over 4m/s, the turbine rotates freely by exceeding this holding torque (cogging torque).

• **I have a V7 wind turbine which is connected to an inverter. The system is on-grid and working well, but how can I improve its efficiency?**

The V7 wind turbine is a vertical wind turbine. It can start its rotation even at 3m/s wind speed depending on which blades you use. On the other hand, every inverter has a different minimum DC startup input voltage, it varies from 50V to 80V for TESUP-recommended inverters. If your wind speed is not high enough to generate the required voltage, the inverter will not start operating and won't transfer your wind turbine's power to the electricity grid.

**Are there any precautions I should take in very windy weather?**

Our wind turbines are very robust and durable. They operate safely in normal windy conditions. If a hurricane scale III (50–58 m/s) or above occurs, please cover wind turbine blades. If you live in a very windy location, we recommend you have a suitable cover (or an item to be used as a cover) in hand to be ready for emergencies.

• **What are the weights of TESUP Wind Turbines?**

- TESUP H7 7KW Horizontal Wind Turbine is 40 kg / 88 lbs.
- TESUP V7 7KW Vertical Wind Turbine with low wind speed blades is 36.5 kg / 80 lbs.
- TESUP V7 7KW Vertical Wind Turbine with moderate wind speed blades is 34 kg / 75 lbs.
- TESUP V7 7KW Vertical Wind Turbine with high wind speed blades is 36.5 kg / 80 lbs.

• **Are connection cables included in TESUP Wind Turbine packages?**

No, connection cables are not included because the cable size and quantity depend on the location of your wind turbine and its distance to the other components of your energy system.

• **What are the differences between the new HERA Wind Pro and the ATLAS Series?**

TESUP HERA Wind Pro is our most efficient and sleek vertical wind turbine with the lowest starting wind speed and the highest power generation capacity.

The key differences between HERA Wind Pro and Atlas 7 & X7 are the following:

### 1. Lowest Starting Wind Speed

Like ATLAS 7, HERA Wind Pro has the lowest starting wind speed. Its rotation starts at 4 m/s wind speed. Upon rotation, power is generated at even 3 m/s wind speed.

### 2. More Rapid Acceleration

After rotation starts, HERA Wind Pro accelerates more rapidly versus other TESUP Wind Turbines under the same wind speeds.

### 3. New innovative design and more colour options

HERA Wind Pro is TESUP's most innovative, compact, and premium vertical wind turbine design. It is available in 3 modern colour options: Pearl Beige, Pearl Blackberry, and Smoke Grey+Red.

### 4. Less Environmental Impact & Quicker Installation

HERA Wind Pro has a new 2-blade shape that is produced by using less material. As a result, it is lighter, more compact, and has less environmental impact than other TESUP vertical wind turbine models. Since it has fewer blades, its installation process is shorter and takes only 15 minutes.

### 5. New Enhanced Body Design

HERA's new body base allows easier fixing to the surface, provides better protection, and creates a cleaner look.

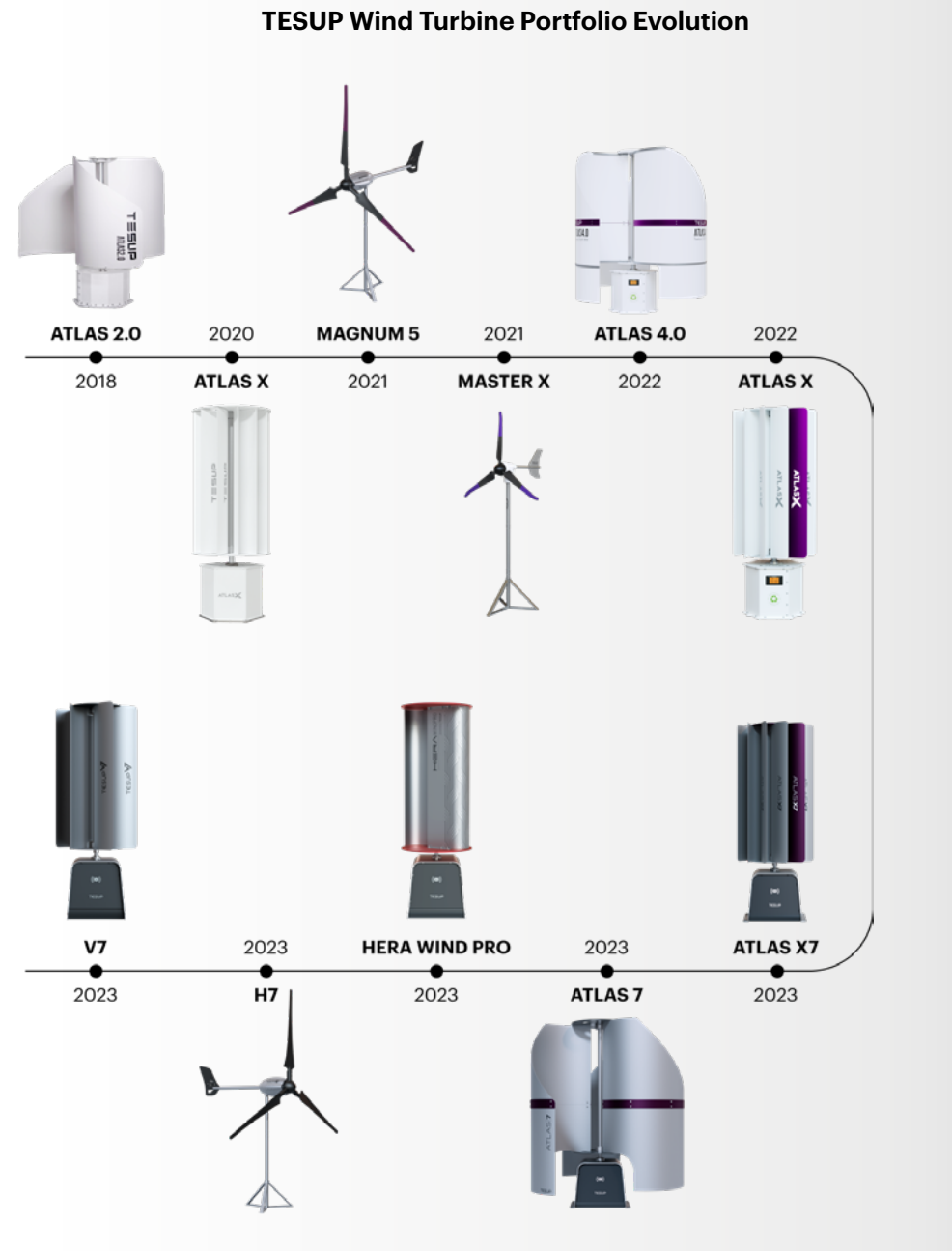

# Charge Controllers

- **Can I use my wind turbine without a charge controller?**

No, you can't use your TESUP Wind Turbine without a TESUP Charge Controller. It is an essential part of the TESUP Wind Turbine System. It controls the wind turbine and acts as a manual emergency brake to protect your wind turbine in the case of an emergency. It is also required to convert AC (Alternating Current) to DC (Direct Current) and control the battery and inverter to prevent overcharging.

- **How many wind turbines can be connected to the TESUP Charge Controller?**

You can connect 1 TESUP Wind Turbine to each TESUP Charge Controller.

- **What is the manual switch (emergency brake) on the charge controller used for, and in what position should it be?**

The switch on the charge controller is a manual braking switch to stop the wind turbine in case of an emergency. In stormy weather, it's better to activate manual braking by turning this switch to the "1" position to protect the system. Under normal weather conditions, the switch button must be kept at the "0" position to continue producing energy.

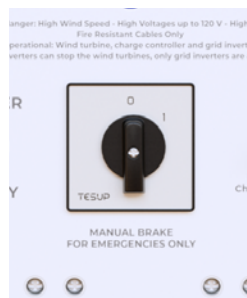

- **What is the potentiometer (Max. Battery Charging Voltage Adjustment) on the charge controller used for?**

If there is a battery in the system, the potentiometer on the charge

controller is used to adjust the maximum limit voltage. In case the maximum limit voltage is reached under very windy circumstances, the controller automatically brakes the system to avoid damage to different parts of the turbine or battery. This maximum voltage value should not exceed 18V for a 12V system, 30V for a 24V system, and 58V for a 48V system.

- **Does the voltage value on the charge controller screen indicate the voltage from the turbine?**

If the charge controller is connected to the battery, the battery voltage is shown on the screen. If the charge controller is connected to an inverter and set to "Inverter" mode, the charge controller displays the voltage from the turbine. But this screen is mainly designed to show the battery voltage. Please do not switch to "Inverter" mode when the charge controller is connected to a battery.

Sometimes, the produced voltage can reach up to 220V. In this voltage range, the PCB board might get damaged. Additionally, during the storm, the charge controller must be manually adjusted up to 120V (maximum). Inverter customers can do this manual adjustment by using their charge controller in battery mode.

- **Is there a brake system on TESUP Charge Controllers?**

Yes, TESUP Charge Controller is an intelligent controller with fully automatic wind turbine protection. It has an electromagnetic braking system and a manual emergency brake button.

- **Is it possible to connect a load directly to the charge controller?**

No, it is not possible. It must be connected to a battery or a grid inverter based on your energy system type. Without the connection to a battery or a grid inverter, a charge controller will not output a steady Voltage and may never function.

### **There is no voltage generated in the system. Is it normal?**

It is not normal. All TESUP products are subject to strict quality control and operation tests before they are packed. Therefore, if your system doesn't generate any voltage, it could be due to a setup or adjustment error.

Please check the following 2 points for the best product performance:

1. If the batteries are full, the charge controller will stop the wind turbine to prevent overcharging. Please turn on some electric appliances or power consumption units to ensure constant consumption from the system and that your turbine keeps rotating and generating energy.
2. If the installation is correct, the maximum charging voltage level must be adjusted via the potentiometer on the charge controller. You should rotate the potentiometer button until the led lamp on the potentiometer goes out. This value should not exceed 18V for a 12V system, 30V of this value for a 24V system, and 58V for a 48V system.

- **When the charge controller is connected, my turbine brakes. Why?**

There are several reasons for braking:

1. If there is not enough load in the system, the system brakes.
2. If the manual brake button on the charge controller is in position "1", then the system might brake.
3. If the charge controller is in battery mode and the batteries are full, the system brakes.
4. Potentiometer adjustment might be wrong. If the led lights up, it means that the system is braking.
5. There might be a short circuit in the system. If two or more phase cables are in contact with each other, the system brakes. Please check this.

6. It might be a smart system and an incompatible device such as Voltronic might be used as the battery inverter. This might have burnt the generator.

- **Does the potentiometer braking option work when the Charge Controller is used in "Inverter" mode?**

No, the potentiometer braking option is only active in "Battery" mode.

- **How can I adjust the potentiometer according to my battery capacity?**

Maximum voltage value should not exceed 18V for a 12V system, 30V for a 24V system, and 58V for a 48V system. Otherwise, the card and screen may burn in the case of excessive voltage.

- **Does the Charge Controller need to be installed indoors or outdoors?**

Our recommendation is to install your TESUP Charge Controller outdoors. The charge controller must be protected from direct rain, snow, and sunlight. So, the outdoor location must be selected accordingly.

- **Can I connect my TESUP Charge Controller to other brands' wind turbines?**

TESUP Charge Controller works only with TESUP Wind Turbines. We don't recommend its use with other wind turbine brands. Any system failure or damage occurring due to its misuse is not under TESUP Warranty.

# Inverters

- **Can I learn TESUP-recommended inverters' startup voltage?**

Our recommended inverters' startup voltage mostly varies from 50V to 80V depending on their model and they keep operation above 50V.

- **Which inverter is the best for wind turbine connections?**

We recommend parallel connection of each wind turbine to a separate inverter. In this way, any operational problems on one wind turbine won't affect the others and the system will continue to generate energy.

- **Can I use a hybrid solar inverter with my TESUP Wind Turbine?**

We don't recommend you connect a TESUP Wind Turbine to a hybrid solar inverter. Parallel connection of every energy generation unit with a separate inverter will maximise the energy generation and avoid big system breakdowns in the case of an emergency or system failure.

The Hybrid Inverter cannot be connected to the battery that is connected to the TESUP Wind Turbine and/or Charge Controller. Any damage to TESUP Wind Turbines occurring due to a hybrid inverter connection is not under TESUP Warranty.

- **Do TESUP-recommended inverters support the hybrid system? Do I need a separate inverter for the solar panels?**

We recommend separate inverters for TESUP Wind Turbines and TESUP Solar Panels. TESUP inverters have 1 MPP tracker and allow a single energy generation unit connection. Every additional wind or solar energy generation unit requires a separate inverter.

# Flexible Solar Panels

- **What are the advantages of flexible solar panels?**

TESUP Flexible Solar Panels have many advantages compared to traditional solar panels. They come with more mounting options and their flexible design can easily fit the shape of any surface without any additional equipment. They can be easily installed on building walls, curved roofs, boats, caravans, and motorhomes. They are lightweight and better suited to roofs that can't take much weight. Their smaller size makes them convenient; they are easy to use in a variety of environments and easy to move from one place to another. Unlike full-sized solar panels, you can carry TESUP Flexible Solar Panels on-the-go, and store them easily.

- **How can I fix the solar panels to a surface? Double-sided tape doesn't seem to be strong enough.**

TESUP Flexible Solar Panels can be installed and fixed on the selected surface via glueing, double-sided adhesive tape, screwing, or drilling. If adhesive tape or glueing is used, you must ensure that the selected adhesive tape or glue is suitable for outdoor applications with a wide temperature range and UV protection. The surface must be very clean and dry to ensure strong attachment.

The double-sided adhesive tape makes a strong immediate bond with the support material and does not allow repositioning. You must not try to move the panel after the adhesive tape application, even if it is only partially attached. Otherwise, you may seriously damage the solar cells. If you prefer glueing, you must leave it for at least 24 hours at normal room temperature after the application to achieve full adhesive strength. If you plan to install your solar panel in a vertical direction that requires

high holding power, screwing would be a safer and stronger option for installation.

For more details, please check [TESUP Flexible Solar Panel User Manual](#).

- **Do flexible solar panels lose efficiency over time?**

Flexible solar panels are typically about 5-10% less efficient than rigid panels, but have a wider variety of applications due to their flexibility and thin size. But the reduction in performance over time is not higher or faster than rigid panels. Generally, all solar modules can be expected to degrade by 0.5% to 2.5% a year.

- **Can TESUP Flexible Solar Panels be used as part of a wind-solar hybrid system?**

Yes, they can be used as part of wind-solar hybrid systems. We recommend a full parallel connection of wind turbines and solar panels to maximise energy generation and avoid system breakdowns in case of an emergency in one part of the hybrid system. A full parallel connection means using a specific charge controller and a specific inverter per energy generation unit. For more details about wind-solar hybrid systems and their connection details, please [check our example connection diagrams](#).

# Energy Systems & Connections

- **How can I sell electricity to the grid?**

Every country has different policies and schemes regarding energy export and selling to the grid. Rules change from government to government, so we recommend you investigate your local country's requirements in detail.

As a general direction, it is possible and supported to sell surplus power generated from your wind turbines and solar panels to the national grid in many countries in the World. You should register under the relevant energy export scheme through your energy supplier in your country. After the registration, you'll get paid for every unit of electricity you feed back to the grid.

- **Do you provide consultancy for energy system designs?**

Yes, our experienced engineers and customer experience team provide customised consultancy services based on your needs. They can support you in designing your bespoke energy system and answer your questions about TESUP products and different types of systems.

- **How do I make the system connections? What do I need?**

System connections change depending on the type of energy system you would like to build: On-grid, on-grid hybrid, or off-grid systems. Please check our example diagrams for [V7](#) and [H7](#) wind turbines to understand the ideal connections per system.

- **Which cable should I use for my wind energy system connection?**

There are multiple factors to be taken into consideration for cable selection.

The quality of the insulation affects the rating of the cable. PVC insulated cable with a temperature rating of 75°C is typically used and recommended. Cable insulated with butyl rubber has a higher temperature rating and can therefore carry higher currents. Additionally, poorly made and corroded connections can introduce very high resistances into a circuit and are probably the most frequent cause of poor system performance.

Tinned cable is the best as this offers superior corrosion resistance to untinned copper wire, particularly in the marine environment. When considering which cable size to use, we recommend you assess the total length of the cable run in metres. Please remember to include the height of any mounting tower or tube, then multiply this by two, which gives the total circuit length.

The section of the cables can be decided depending on the number of units in the system and their distance from each other.

For the best results, we recommend you get installation support from an electrical engineer or electrician who is an expert in this area.

- **How can I be sure that my wind turbine system is working well?**

The first step to assess the performance of your wind turbine system is to check the power curve for that particular wind turbine (Wind speed versus electrical power generated). This curve shows how efficiently the turbine converts the wind energy into electricity.

The actual performance of your system will be affected by local wind conditions, nearby obstructions, power demand profiles, and a range of other factors, such as connections and the quality of the materials used. So the power curve on its own might not match your exact power generation, but the values should be reasonably close if everything in the system works well.

- **I already have a solar system, but I want to integrate a TESUP Wind Turbine into it. How can I do it?**

The best way to include TESUP Wind Turbine in your existing solar system is to create a full parallel connection consisting of the TESUP Wind Turbine and TESUP Charge Controller.

If your system is off-grid, the TESUP charge controller must be connected to your battery. If your system is on-grid, the charge controller must be connected to a separate inverter that will be directly connected to the grid.

Our recommendation is to use a separate inverter for the TESUP Wind Turbine to ensure the system's operation and continuous energy generation in case of any failure in your solar system.

Please [click here](#) to learn about system connections and check our example diagrams.

- **Can I combine solar and wind energy products and create a hybrid system?**

Yes, you can. Please check our connection diagram for hybrid systems to learn about its details. [Click here](#).

- **How far should the wind turbine, charge controller, and inverter be positioned from each other?**

It depends on the location and the height you plan to install your wind turbine. The higher the wind turbine is, the better it catches the wind. Naturally, there will be a certain distance from the wind turbine to the charge controller as one will be at the top of a roof, tower, or pole; and the other will be on the ground level. But the charge controller should be positioned as close to the wind turbine's horizontal projection line as possible but in a protected location. The charge controller and inverter

should be located next to each other or very close to each other to avoid excess cable usage and reduction in energy transmission.

- **How can I calculate the yearly power generation amount for specific TESUP products?**

In real life, there will be multiple factors affecting the power generation of your wind turbine such as its height, connection quality, cables used, and the efficiency of other system components. But in order to make an estimated calculation for the ideal conditions, you can check the power curve of the TESUP Wind Turbine. You should take a few things into consideration for the estimated yearly power generation. These are the average wind speed for the selected location, hours of wind per day, wind turbine's power generation capacity at the location's wind speed, number of days that the wind turbine is expected to operate, and any additional factors that might affect the efficiency of the system and can be used as a multiplier.

You can also check our saving calculator to calculate your estimated yearly savings per TESUP product. You can find the TESUP Saving Calculator at the bottom of this page.

# Warranty

- **Do TESUP products have a warranty?**

Yes, all TESUP products come with a standard 2-year TESUP Care Product Warranty. Customers can also extend TESUP Care Product Warranty by paying extra for selected TESUP products.

- **What is covered in TESUP Care Product Warranty?**

Any failure occurring due to a defect in the original product despite its intended use is under TESUP Care Product Warranty, and our after-sales support team will be responsible for solving your problem. Any product or system failure occurring due to customer misuse is not covered under TESUP Care Product Warranty. You can read potential misuse situations in specific product user manuals. Each TESUP product features custom-built software personalized with the customer's name. Please be aware that once an order is placed and processed, modifications to the software remotely are not possible, and consequently, we do not offer refunds.

For products under warranty experiencing manufacturing defects or malfunctions, customers must send them to our London repair center for examination. While shipping costs for returns are the customer's responsibility, if the fault is attributed to the production process, these costs will be reimbursed. In such cases, a new replacement product with free delivery will be promptly sent.

To learn more, please [click here](#) in order to read our Terms & Conditions.

- **Can I extend my TESUP Warranty? Do you offer such an option?**

Yes, we extend TESUP Care Product Warranty for selected TESUP products. Please contact our after-sales support team to get more information about this service.

- **If I face any problem, how can I reach you? Do you have any call centre or support?**

Yes, we have an amazing customer experience team, and they provide each TESUP customer with the right customised service. For any inquiries, please reach out to them by logging into our Support Page and selecting the 'Chat' option located at the far right end of the page. One of our experts will contact you as soon as possible.



Before You Go

## 6 Vital Steps to Remember Before You Go

There are steps you can take to optimise your TESUP product and extend its operational life. Here are some tips for getting the best performance from your product:

- 01 Regular maintenance:** Follow the provided schedule for inspections, cleaning, lubrication, and necessary adjustments or replacements.
- 02 Quality components:** Use compatible, high-quality components like charge controllers, inverters, and batteries.
- 03 Consider environmental factors:** Protect the turbine from extreme weather, corrosive environments, and excessive dust or debris.
- 04 Proper usage:** Operate the turbine according to the manufacturer's instructions and avoid exceeding specified operating parameters.
- 05 Monitor and troubleshoot:** Regularly check performance and address any issues promptly to prevent further problems.
- 06 Seek professional assistance:** Consult qualified professionals or contact TESUP Customer Experience team for maintenance or optimization help.

By following these recommendations, you can maintain your turbine effectively, optimise performance, and extend its lifespan.



An aerial photograph of a dense forest of evergreen trees. A dirt road winds through the trees from the top center towards the bottom left. In the middle of the road, there is a red container or trailer. The overall scene is lush and green.

**Making the World a Better Place**  
One Household at a Time.

**TESUP**